



LAYERZERO
POWER SYSTEMS, LLC.

The Foundation Layer

Series 70: eSTS

3000 A 277/480 V 4-Pole Static Transfer Switch



Product Brochure

The LayerZero eSTS Static Transfer Switch Maximizes Power Reliability

eSTS Automatically Transfers Between Two or Three* Power Sources

LayerZero Power Systems designs and manufactures the world’s **most reliable** static transfer switch. The Series 70 eSTS is a solid-state transfer switch that automatically or manually provides solid-state transfers between two in-phase AC sources in a quarter cycle. The eSTS performs open-transition transfer in such a manner that the connected load disruption is minimized without ever cross-connecting the power sources. One power source is selected to be the preferred source. If the preferred source fails, the load is automatically and seamlessly connected to the alternate source by means of an open-transition static transfer. For emergency transfers between asynchronous sources, dynamically phase-compensated transfers minimize saturation of downstream transformers in 3-phase, 3-wire eSTS.

*Optional

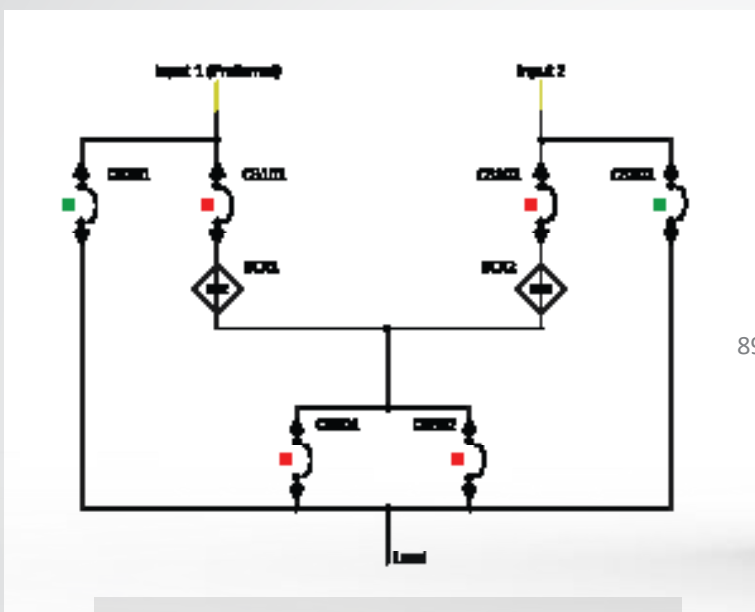

eSTS Static Transfer Switch One Line Diagram



Standard Features

Reliability



Optional Triple Modular Redundancy:
TMR Contains Fully-Independent Control Paths With No Single Point-Of-Failure



Safe Bypass Procedure:
Mechanical Bypass Interlock Eliminates Human Error When Performing Bypass Procedures



Voice Guided Bypass:
Step-By-Step Instructions With Audio and Video Guidance To Assist Operators Through Bypass

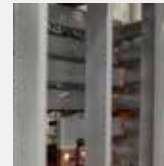

Epoxy Coated Buswork:
Maximizes Reliability By Eliminating The Possibility of Bus-To-Bus Faults



Silver Plated Terminals:
Silver Has Excellent Conductivity To Provide Superior Electrical Performance and Reliability



Maintenance-Free Joints:
Brazed Joints Are Permanent And Maintenance-Free, Maximizing Product Life



Machined Hardware:
Machined Cap Screws and Engineered Disc Springs Maintain Constant Torque Throughout Product Life



Optical Fiber Based Controls:
Eliminates Noise and Interference While Isolating Components from High Voltage



Serialized Critical Board Tracking:
Critical Boards Are Serialized And Cataloged in an Active Database For Traceability

Safety



INSIGHT IR® Cameras:
Built-in Infrared Cameras to Continuously Scan Bolted Connections For Irregular Rises In Temperature



Sectionalized Components:
Isolated Sections That Can Be Safely De-Energized For Performing Maintenance



Dead Front Hinged Doors:
Barrier To Provide A Safe Working Area With No Exposed Live Parts

Connectivity

Ethernet Connectivity:
Secure VPN Router Connects To Network For Advanced Remote Monitoring Capabilities

Modbus/TCP:
Open Connectivity to Existing Monitoring Systems Without Proprietary Limitations

NTP Time Clock Synchronization:
Facilitates Timeline-Based Logging For Post-Event Reconstruction

SNMP Connectivity:
Permits Remote Management Via Simple Network Management Protocol

Power Quality Monitoring

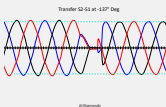

Real-Time Waveform Capture:
Automatically Captures A Picture Of The Power Three-Cycles Before and After Every Event

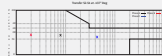

ITIC Plotting:
Generate ITIC Plots To Determine if Connected Equipment Was Affected by Power Quality Events



Local Touch-Screen Interface:
Password-Protected Color Touch-Screen GUI For Local STS Setup/Operation/ Administration



Waveforms Automatically Emailed:
Capability to Send Waveform Captures To Designated Individuals For Every Transfer

Generate Easy-To-Understand Power Quality Reports with ITIC Plotting

All LayerZero Power Systems products have on-board power quality analyzers that break down power sources into samples. If the power quality goes out of specification of a source, eSTS will transfer to the alternate source, automatically generating waveform captures and VDAT-generated ITIC curves of the event. This data is remotely accessible by connecting to the unit via a web browser.

VDAT (Voltage Disruption Analysis Tool) is a quantum leap in the field of power systems data interpretation. By harnessing exceptional algorithms and processing techniques, VDAT effortlessly translates complex power data into discernible, actionable insights. VDAT tackles a major industry challenge: while traditional waveform captures are often intricate and challenging to interpret, VDAT brings clarity with its intuitively designed plots based on Information Technology Industry Council (ITIC) standards, empowering professionals to make quick and informed decisions.

In the test below, the STS was connected to two sources 150° out of phase. Source 2 breaker was opened, causing the STS to perform an automatic transfer to the primary source. A delayed transfer occurred, causing events on phases A, B, and C, automatically generating ITIC plots. Unlike waveform captures, ITIC plots are easy to read and do not require expert analysis to understand.

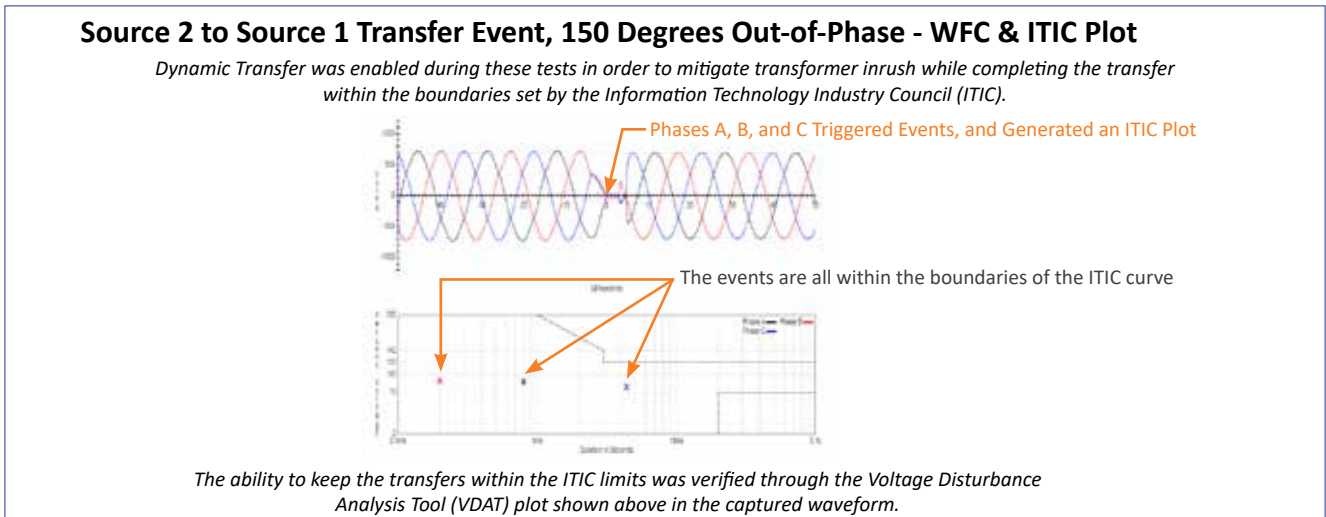
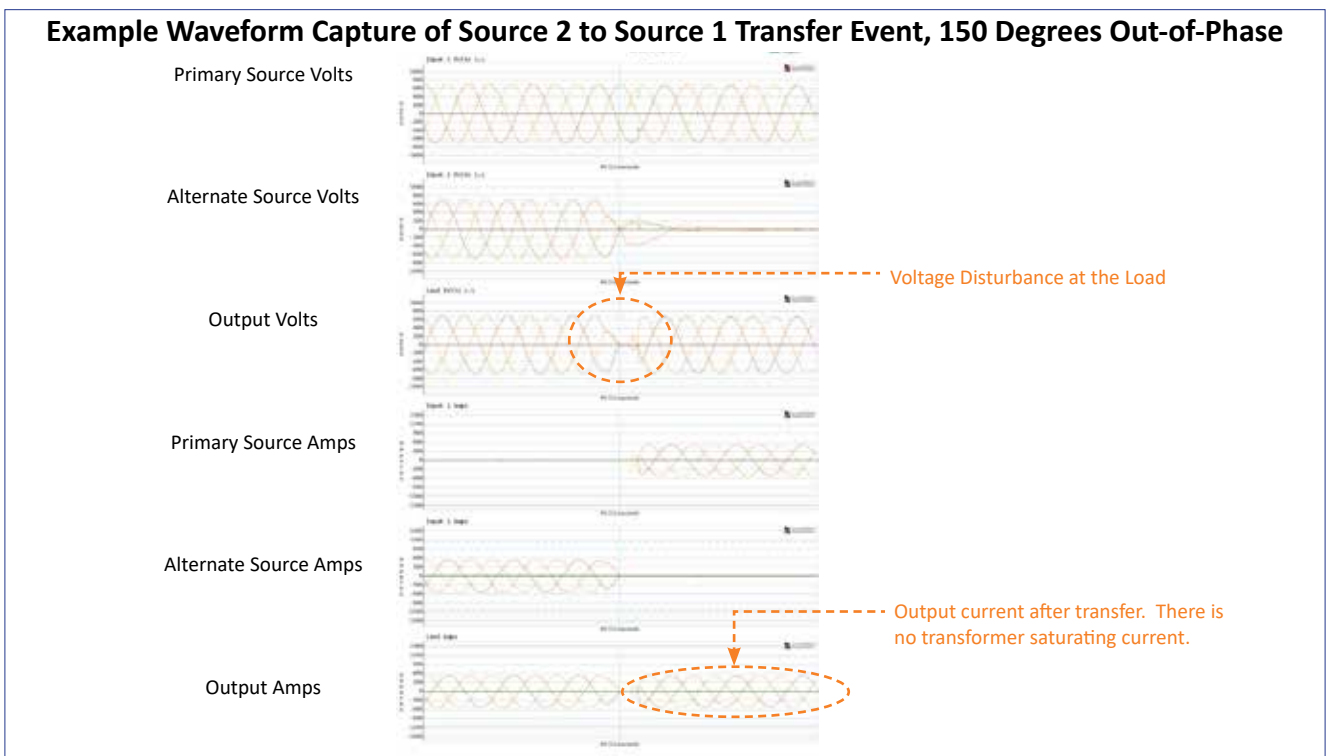

Control Electronics

- System Control & Data Acquisition Boards
- SCR Gate Drives
- Redundant Power Supply System
- I/O system; VPN Router

Power electronics

- SCRs (Silicon Control Rectifier) in Forced-Air Cooled Heat Sinks

CB Section Contains:

- Input isolation switches
- Bypass isolation Switches
- Output isolation switches
- Source connection terminals
- Load connection terminals



Heat Sinks and SCRs

CB101 Source 1 Isolate
CB102 Source 2 Isolate

CB201 Bypass Isolate, Source 1
CB202 Bypass Isolate, Source 2 (Redundant, Optional)

CB301 Output Isolate 1
CB302 Output Isolate 2,

Reliability Overview

LayerZero eSTS Reliability Overview

The LayerZero eSTS Provides Many Dimensions of Reliability:

- Control System Reliability
 - SMR (Single Module Redundancy, Standard)
 - TMR (Triple Modular Redundancy, Optional)
- Control Power Supply Reliability
- Signal Reliability
- Operator Procedural Reliability



Single Module Redundancy (SMR) Reliability (Standard)

Single Module Redundancy (SMR) is a cost-effective topology that provides redundant power paths to mission-critical equipment. In SMR systems, sources each source has built-in triple redundancy of processors. Additionally, each phase is controlled by a separate gate drive board.

LayerZero Single Module Redundancy topology is unique in that it is fail-safe, maintaining full switching functionality even if a critical board were to fail.

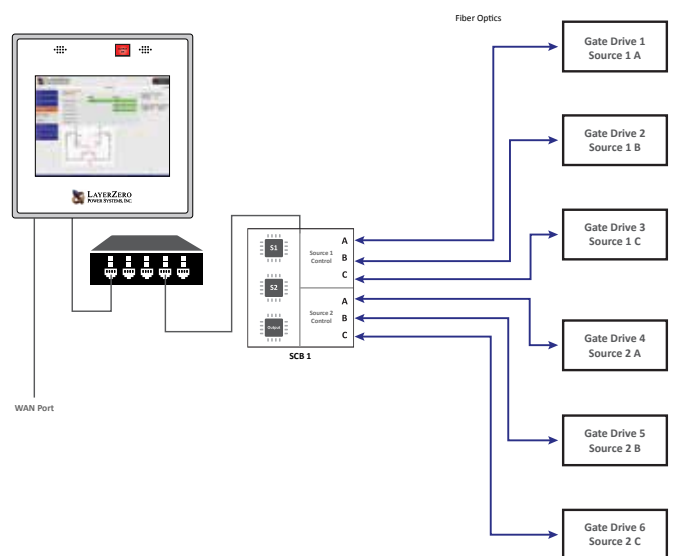

Reliability Features: Triple Modular Redundancy (TMR) *Optional

Triple Modular Redundancy (TMR) Reliability (Optional)

LayerZero TMR has all the redundancy of SMR, plus each STS has three independent sets of analog and digital data acquisition and control systems. There is no direct communication between the three systems. The three systems do not even share a common system clock.

- Each control system acquires voltage and current data independently
- Each control system determines whether a source is good/bad independently
- Upon loss of a source, each control system makes decisions to transfer independently

Even if an entire control path or its subcomponent were to fail; and then if the active power source were to fail, the STS is able to complete its mission of transferring to the alternate source.

Triple Modular Redundancy, a proper noun, is based on proven statistics and stringent mathematics. There are similar-sounding terms, like tri- or triple-redundant, used in industry to describe other STS products, but they simply don't yield the same high level of reliability.

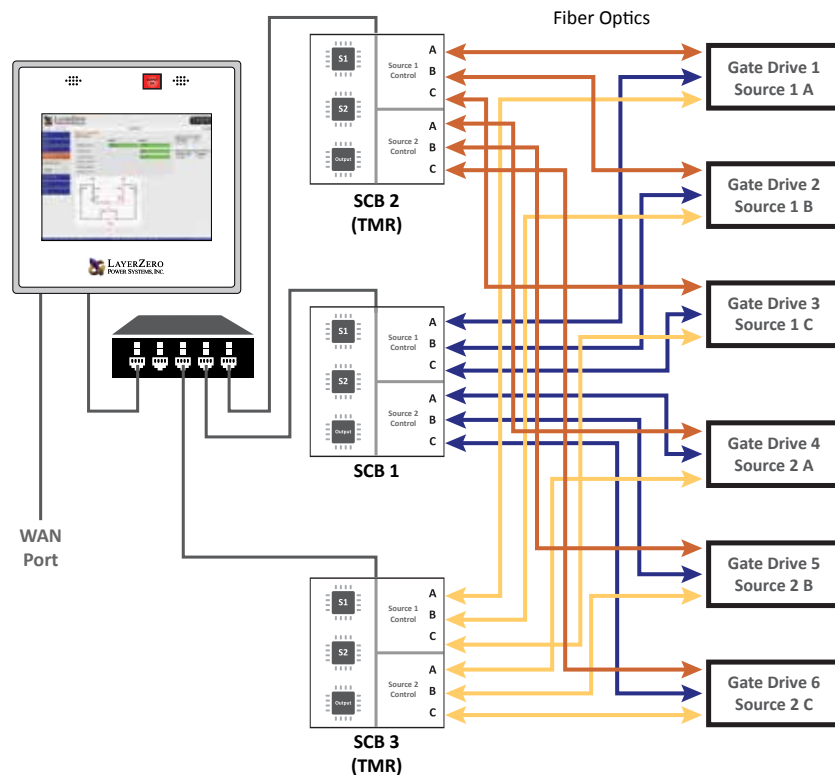

Reliability Features: Single Module Redundant (SMR) Redundancy

eSTS SMR Triple Redundant Power Supply Architecture

Divided into four (4) logical failure groups:

- System controls
- Source 1 gate drives
- Source 2 gate drives
- Peripherals.

The three (3) available source of power from which to supply control power to each failure group are:

- Source 1
- Source 2
- STS Output.

LayerZero’s STS design incorporates 12 power supplies (3 power sources x 4 failure groups). The resultant control power topology utilizes all possible power paths to the 4 logical STS failure groups and is the most comprehensive and redundant power supply system in existence.

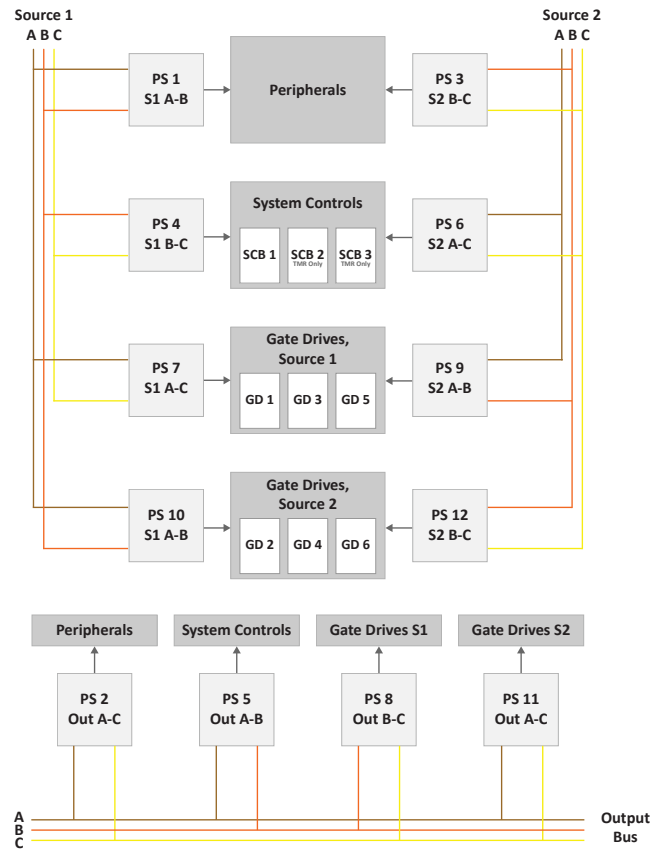

eSTS SMR Triple Redundant Processors

- Separate/independent processors for Source 1, Source 2 and Output power quality analysis.
- If Source 1 processor malfunctions then system is able to be commanded to transfer to Source 2; & vice versa.
- If main control system fails then STS continues to conduct power to the load from the existing source of power. (However STS is unable to transfer to the other source).
- Each phase of each source is controlled with a separate gate drive circuit board.

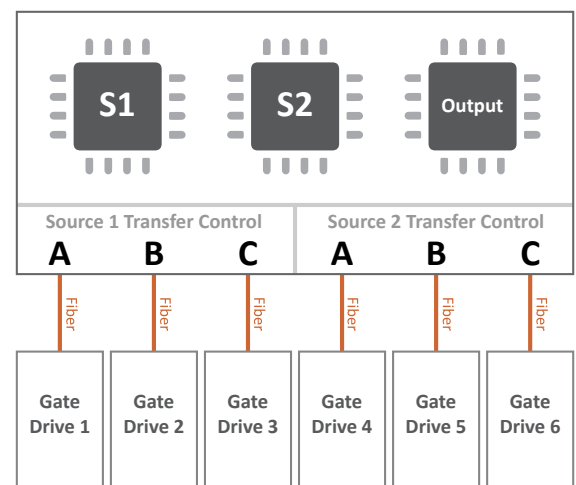

Reliability Features

Mechanical Bypass Interlock

In order to minimize the possibility of operator error during equipment bypass operations, LayerZero provides:

1. Interlocked breakers
2. Mechanisms to ensure that a source cannot be bypassed without the STS on the correct source.
3. Safeguards to make certain that sources cannot be connected to each other inadvertently.
4. A voice-prompted bypass procedure that guides the operator through the sequence.
5. A step-wise pictorial & video presentation is provided on the touch-screen display during bypass.

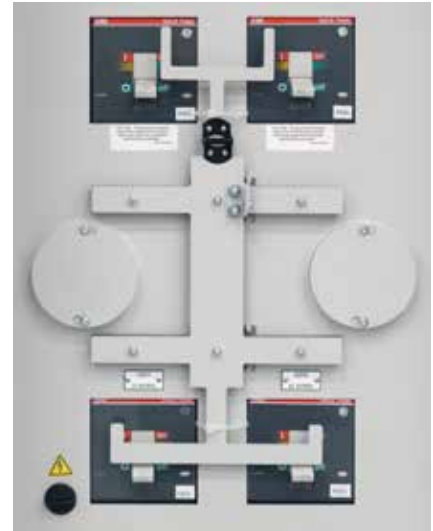

Voice Guided Bypass

Operator error during maintenance bypass has long been recognized as a reliability hazard. To help prevent operators from completing the bypass procedure out of sequence, LayerZero products feature a voice-prompted bypass procedure. The system instructs the operator through a clear, step-by-step sequence, with only one operation presented per screen. Visual and audio cues provide unambiguous guidance throughout the process, reducing the probability of operator error and enhancing overall safety.



Forced Air Heat Dissipation System

The LayerZero 3000 A Series 70: eSTS Static Transfer Switch is equipped with a forced air-cooled heat dissipation system, a proven technology that delivers reliable and consistent thermal management. Forced air cooling provides an efficient method for heat dissipation, ensuring stable operating temperatures and helping to maximize the lifespan of critical components.



Reliability Features

Epoxy Coated Buswork/Maintenance Free Joints

LayerZero's use of epoxy-coated buswork ensures safety and reliability by eliminating the possibility of bus-to-bus faults. All bus joints are permanently brazed, resulting in a maintenance-free, long-lasting design.

Silver Plating

To achieve the highest possible performance, LayerZero utilizes silver plating on all bus joints and terminals. Silver's exceptional conductivity and low electrical resistance provide superior contact reliability and performance consistency.



Machined Hardware

Bolted connections in LayerZero systems use precision-machined cap screws and engineered disc springs. This design delivers a flat pressure-versus-deflection profile, ensuring all bolted connections maintain constant torque throughout the product's lifetime. These technologies have been rigorously tested in environments with wide temperature variations to ensure that, once tightened, connections remain secure for the life of the equipment.



Fiber Optic Controls Increase System Reliability

Fiber-optic-based controls eliminate electrical noise and interference while isolating low-voltage control circuits from high-voltage components. Optical fiber allows reliable signal transmission while protecting sensitive electronics. In LayerZero's eSTS design, gate drives, operating at power circuit voltage, receive control signals through optical fibers, improving reliability and reducing susceptibility to electrical disturbances.

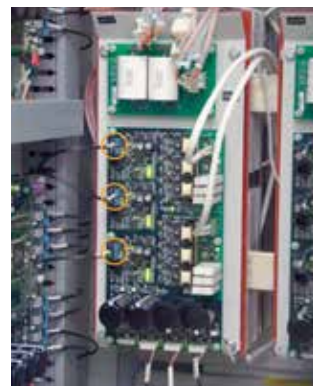

Safety - Ease of Maintenance

INSIGHT™ IR Portholes Permit Scanning of Bolted Connections with Dead-Front Doors Closed

Strategically positioned IR-scan portholes allow safe thermal scanning of all bolted connections with the dead-front doors closed, protecting operators from exposure to power circuit voltage. Thermal scans can be performed entirely from the front of the unit without ever opening the dead-front door.

The IR window swivels upward and unlocks with keyhole access, revealing a protective mesh that allows the operator to safely aim and capture thermal images.

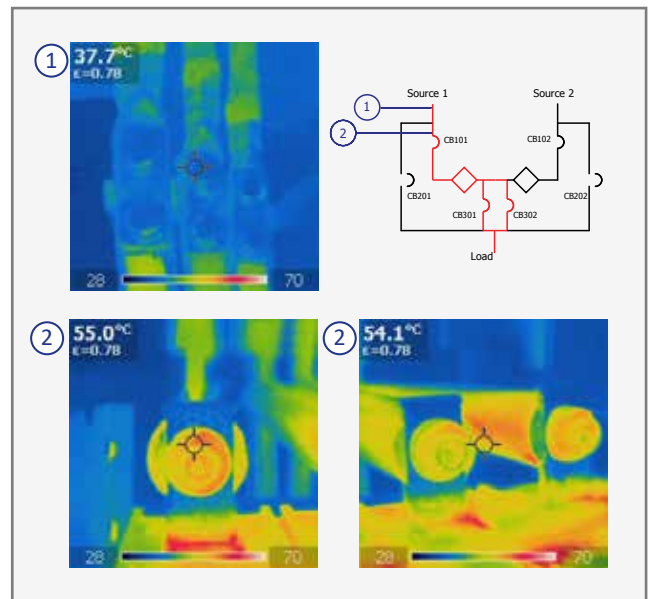

IR Portholes in eSTS
(Door and side panel hidden for visibility)

Safety - Ease of Maintenance

INSIGHT IR® Provides Early Detection of Thermal Issues

INSIGHT IR® is a continuous thermal monitoring system designed to detect temperature anomalies in critical components before they cause downtime. The system captures data from a network of fixed infrared cameras, displaying live temperature images of each connection.

INSIGHT IR® provides temperature data by phase, enabling early identification of thermal trends. Detecting and addressing potential issues before they escalate ensures safer, more reliable operation of mission-critical systems.



INSIGHT IR® live images can be viewed on a local or remote display.



INSIGHT IR® Camera Housing



INSIGHT IR® generates a hybrid heat map over a visible image

INSIGHT IR® Cameras are installed near bolted connections and critical components

Safety

Sectionalization Maximizes Operator Safety

Operators are well-protected from exposed connections. Normal operator sections (breakers and switches) are physically separated from the power electronics and control electronics sections, allowing maintenance to be performed safely. If service is required on a particular section, power can be bypassed to another, ensuring repairs can be completed without exposure to energized components.



View Status LEDs and Distribution CB Positions With Dead-Front Doors Closed

Our Series 70 product line was inspired by NFPA-70E, to help data centers drastically reduce the risks of their energy distribution systems.

Operators can view the status of diagnostic LEDs without exposure to the energized power electronics section. In addition, SafePanel circuit breaker positions can be viewed with the dead-front door closed.



Ease of Maintenance/Connectivity Options

Front and Rear Only Access Saves Space

The Series 70: A eSTS is designed to be installed, operated, diagnosed and maintained only from the front and rear. The dead-front panels are hinged, and side or rear covers never have to be removed.

Unhinged covers can be bulky and unwieldy, and operator error during removal and replacement of covers has been known to cause mishaps and compromise load reliability. A safe, non-invasive operation and maintenance regime results in a higher reliability of the critical load.

The Series 70: eSTS utilizes dead-front hinged doors. An alarm notifies when an outer door has been opened.



eSTS Front



eSTS Rear

eSTS Connectivity Options

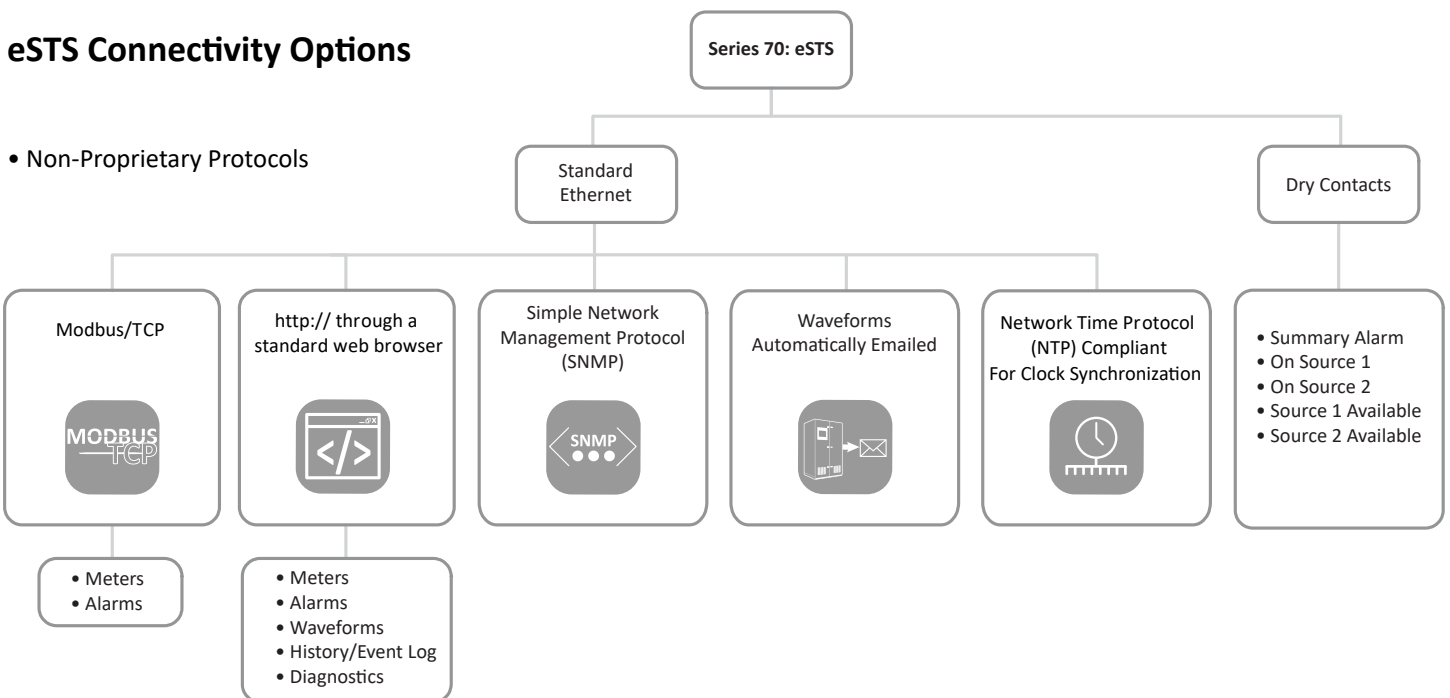

Features/Power Quality Monitoring

LayerZero Power Quality Monitoring

LayerZero PQM (Power Quality Monitoring) keeps you aware of all activity within your critical power distribution systems. It is a comprehensive monitoring platform featuring both local and remote communication capabilities. From basic monitoring and alarms to advanced power quality analytics, LayerZero PQM offers a wide range of tools designed to help maintain the highest level of system reliability.

LayerZero PQM provides a vendor-neutral “Bird’s Eye” view of your entire critical power distribution infrastructure. It maximizes reliability by alerting you when a source exhibits quality issues, when a UPS output degrades, or when alarms occur. Additionally, LayerZero PQM allows users to trace the exact sequence of past events, empowering facilities with the ability to perform detailed forensic analysis of power disturbances.

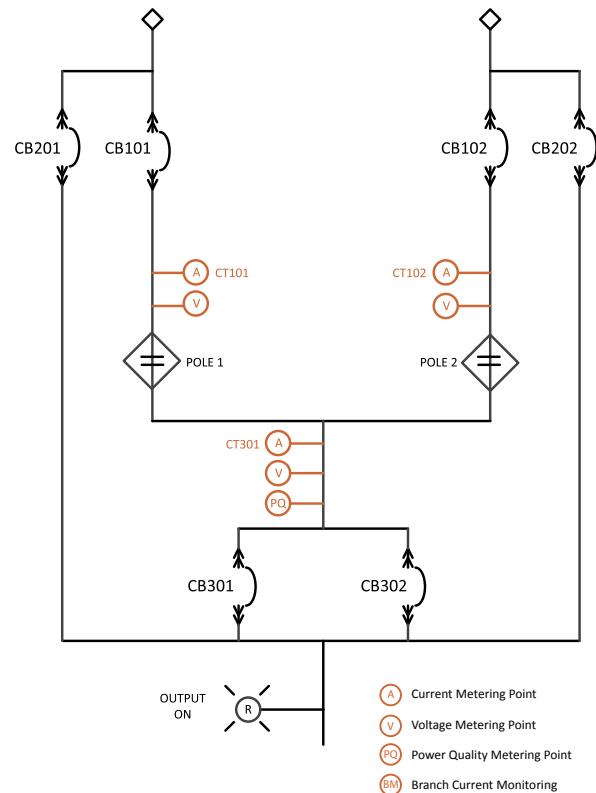

15" Color Touch Screen (Standard)

1. Stereo Speakers for Guided Bypass Prompts
2. Output On Light (Remains Lit in Bypass Isolate Mode)
3. Alarm & Bypass Indicator
4. SCB Status Indicator
5. Logged In User
6. Navigation Menu
7. Customer & Project Information
8. Date & Time

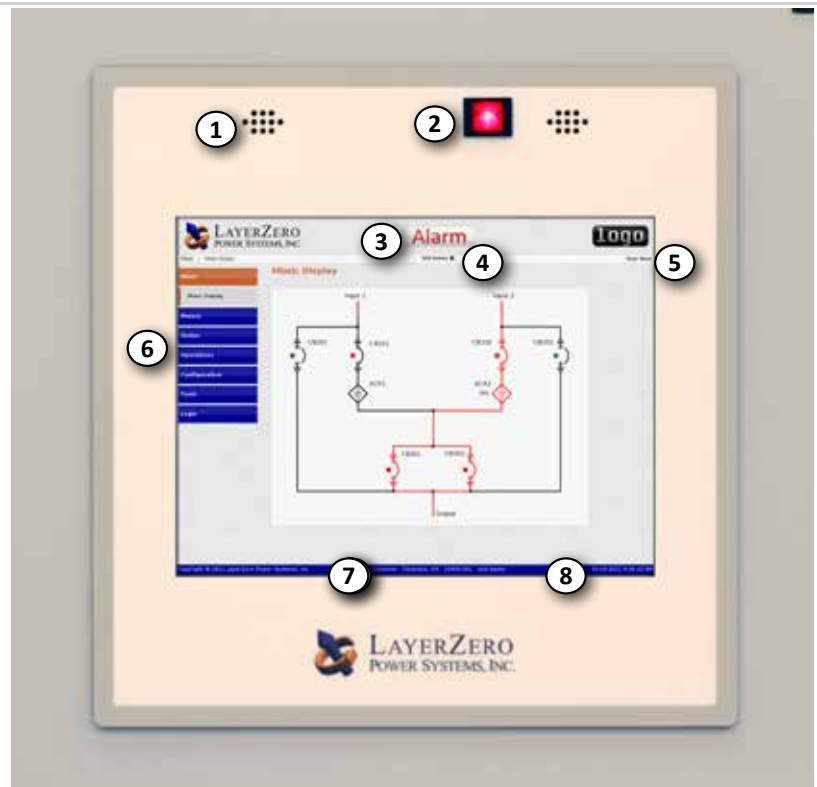

Power Quality Monitoring

Static Switch Power Quality Monitoring

The Series 70: eSTS is equipped with LayerZero (Static Switch Quality Monitoring), a comprehensive monitoring system with both local and remote communication options.

From standard monitoring and alarm reports to advanced waveform analysis, LayerZero SSQM enables operators to stay aware, vigilant, and proactive in maintaining a safe, stable, and reliable environment.



LayerZero's SSQM Provides Answers

LayerZero SSQM records timestamped waveform snapshots before and after events, giving users detailed insight into power quality anomalies. This data enables facilitators to reconstruct events and identify the root causes of disturbances. LayerZero continuously captures power quality information at the STS< PDU, and PRR levels, supporting comprehensive post-event analysis and data-driven decision-making.

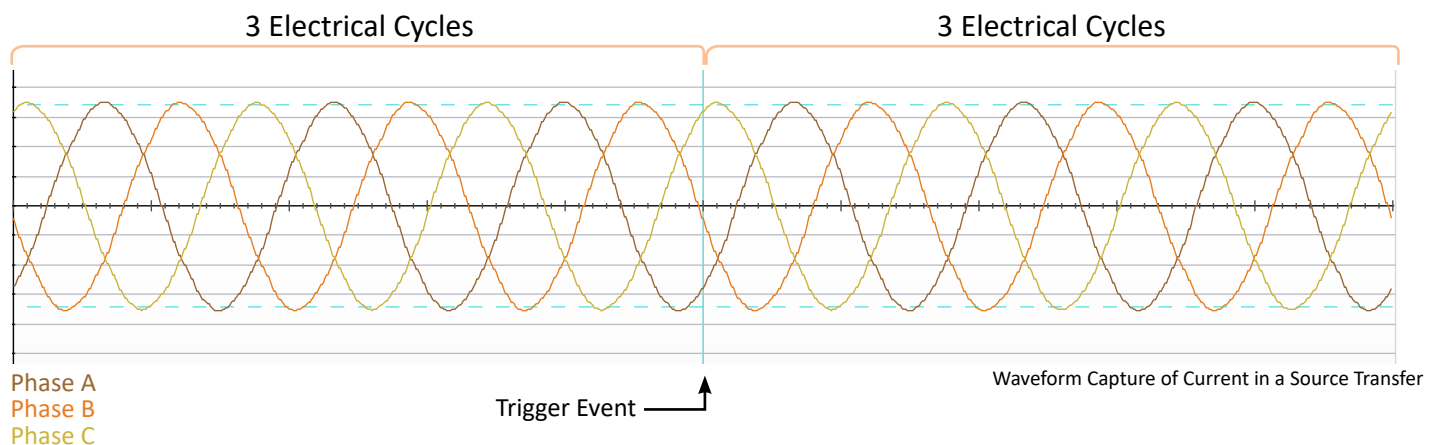

LayerZero SSQM Technical Specifications

LayerZero SSQM Parameters		Mains
Voltage Inputs and Output	Voltage (Volts)	✓
	Voltage Average of Phases (Volts)	✓
	Frequency (Hertz)	✓
	Total Harmonic Distortion (Percent VTHD)	✓
	Phase Rotation	✓
Current Inputs	Current (Amps)	✓
	Current Average of Phases (Amps)	✓
	Current Imbalance (Percent)	✓
	Real Power (kilowatts)	✓
	Apparent Power (kilovolt-amperes)	✓
	Reactive Power (kilovolt-amperes reactive)	✓
	Power Factor	✓
	Crest Factor	✓
	Crest Factor Average of Phases	✓
	Phase Difference Between Sources	✓
	Phase Difference Between Sources and Output	✓
Alarms	Summary Alarm	✓
	On Source (1/2/3)	✓
	Source Fail (1/2/3)	✓
	Source Preferred (1/2/3)	✓
	Source 1st Alternate (1/2/3)	✓
	Source Over/Under Voltage (1/2/3)	✓
	Source Over/Under Frequency (1/2/3)	✓
	Source Not Available (1/2/3)	✓
	Output Failure	✓
	Source Overcurrent (1/2/3)	✓
	Source Exceeds Manual Limit (1/2/3)	✓
	Source Exceeds Automatic Limit (1/2/3)	✓
	Bypassed to Source (1/2/3)	✓

Technical Specifications: 4-Pole Static Transfer Switch

Mechanical Characteristics *	
Current/Voltage/Number of Poles	3000 A 277/480 V 4-Pole
Heat Dissipation	Please contact LayerZero engineering
Weight	11,200 lbs [5080kg]
Dimensions	89" x 192" x 57" (2263 mm x 4883 mm x 1448 mm)
Clearances	FRONT: 42 IN. [1067] REAR: 42 IN. [1067] SIDES: 4 IN. [101] TOP: 18IN. [457]
Frame Construction	Welded Frame
Electrical Connections	Silver-Plated Solid Busbar
Color	Textured Powder Coat White (RAL 7035), Blue (RAL 5017), Black, Custom
Floor Stands	Optional
Seismic floor stands	Optional
Junction Boxes	Optional
Sectionalization	Engineered Composite Insulation, Dead Front Doors
Electrical Characteristics	
Number of Inputs	2, 3 (3 optional)
Number of Output CBs	1, 2
Frequency	50 Hz, 60 Hz
Poles	3-pole
Phases	3 Phase, 3 Wire, 4 Wire + Ground
Neutral Rating	100%, 150%, 200%
Transfer Time	Nominal 1/4- cycle for in-phase sources
Redundancy	Single Module Redundancy, Triple Modular Redundancy (Optional)
Circuit Breaker Type	Molded Case Switch (Standard), Electronic Trip (Optional)
Circuit Breaker Mounting Type	Plug-In up through 600 A; Draw-out 800 A, 1200 A
TVSS	Standard
Power Quality Monitoring	
Power Quality Monitoring Technology	LayerZero Power Quality Monitoring
Waveform Capture	Local Display, Remote Display via Web Browser, Waveforms Automatically Emailed
Voltmeter	Input sources and Output, for each phase
Ammeter	Input sources and Output, for each phase
Frequency Meter	Both Sources
Synchroscope	Phase Angle Meter Between Sources
Metering	Apparent Power, Real Power, Power Factor, Output Total Harmonic Distortion
Time Stamped Transfer Count	From First Day Use, From Last Reset
CB Status Indicator	Open/Closed/Tripped Circuit Breaker
Source Indicator	Preferred Source
Power Path Indicator	On Live Mimic

*Dimensional & weight data is only valid for 2-source.

All product specifications are subject to change without notice.

Technical Specifications

Operational Characteristics	
Transfer Modes	Automatic; Manual (via Preferred Source Selection)
Inrush Mitigation Technology	Patented Dynamic Phase Compensation Algorithm (U.S. Patent 7,589,438 B2)
Cooling	Forced Air Cooling
Cable Access	Top/Bottom
Service Access	Front And Rear
Bypass Interlock Mechanism	Mechanical
Noise & Interference Isolation	Optical Fiber in Critical Control Paths
IR Scan Port Type	INSIGHT IR® Portholes
SCR Type	Puck
Display Type	15" Color Touch Screen
Display Resolution	1024x768
Bypass Assistance	Voice-Guided Bypass
Audio	Bezel-Mounted Stereo Speakers
Languages	English, French
Mimic Panel	Digital
Setpoints Control	Digital
Power Supplies	Redundant (4 Failure Groups. Triple Redundant Supplies. 12 Power Supplies Provided.)
Connectivity	
Meters	Local Display, Ethernet, Modbus/TCP, http via Web Browser (Non-Proprietary)
Alarms	Local Display, Ethernet, Modbus/TCP, http via Web Browser (Non-Proprietary)
Summary Alarm	Dry Contacts; Local Display; Modbus/TCP; Web Browser
Waveforms	Local Display, Ethernet, http via Web Browser (Non-Proprietary)
History/Event Log	Local Display, Ethernet, http via Web Browser (Non-Proprietary)
Diagnostics	Local Display, Ethernet, http via Web Browser (Non-Proprietary)
Time Synchronization	Network Time Protocol (NTP)
Standards Conformance	
CSA	ETL Listed to C22.22 No 107.
UL	ETL Listed to UL 1008S

All data tables above are for 3-pole only. Contact LayerZero for custom sizes and designs.

All product specifications are subject to change without notice.

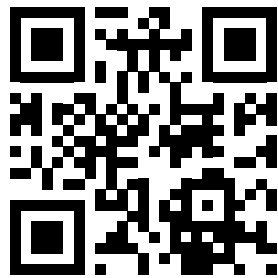

Learn more at www.LayerZero.com



LayerZero Power Systems, LLC.
1500 Danner Drive
Aurora, OH 44202 U.S.A.

© 2026 LayerZero Power Systems, LLC.

[LayerZero](#)®, INSIGHT IR®, SAFEARM®, SAFEPANEL®, and LayerZero Power Systems, LLC.® are registered trademarks of LayerZero Power Systems, LLC. All Rights Reserved.

All product specifications are subject to change without notice.

Rev. 4/26 #14