



LAYERZERO
POWER SYSTEMS, LLC.

The Foundation Layer

Series 70: eSTS

1600 A 277/480 V 4-Pole Static Transfer Switch



Product Brochure

The LayerZero eSTS Static Transfer Switch Maximizes Power Reliability

eSTS Automatically Transfers Between Two or Three* Power Sources

LayerZero Power Systems designs and manufactures the world’s most reliable static transfer switch. The Series 70 eSTS is a solid-state transfer switch that automatically or manually provides solid-state transfers between two in-phase AC sources in just a quarter cycle. The eSTS performs open-transition transfers in a way that minimizes load disruption without cross-connecting power sources. One source is designated as the preferred source. If that source fails, the load is automatically and seamlessly connected to the alternate source through an open-transition static transfer. For emergency transfers between asynchronous sources, dynamically phase-compensated transfers are utilized to minimize downstream transformer saturation in 3-phase, 3-wire eSTS configurations.

*Optional

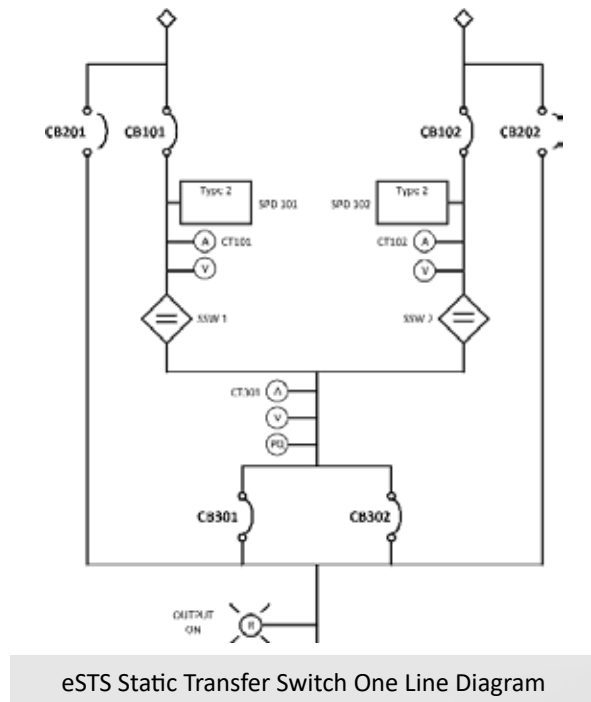

Control Electronics

- System Control & Data Acquisition Boards
- SCR Gate Drives
- Redundant Power Supply System
- I/O system; VPN Router

Power electronics

- SCRs (Silicon Control Rectifier) in Convection Cooled Heat Sinks

CB Section Contains:

- Input isolation switches
- Bypass isolation Switches
- Output isolation switches
- Source connection terminals
- Load connection terminals

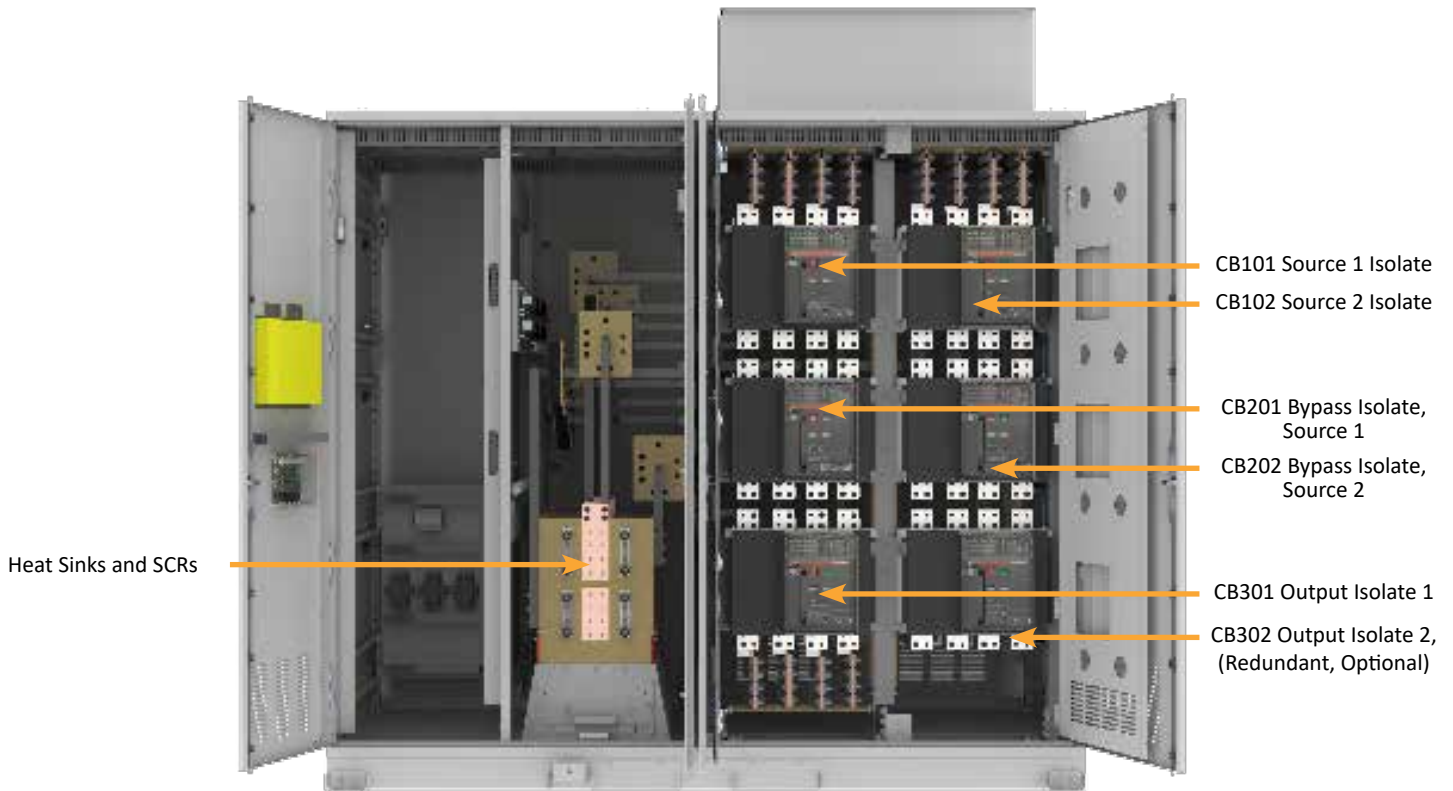
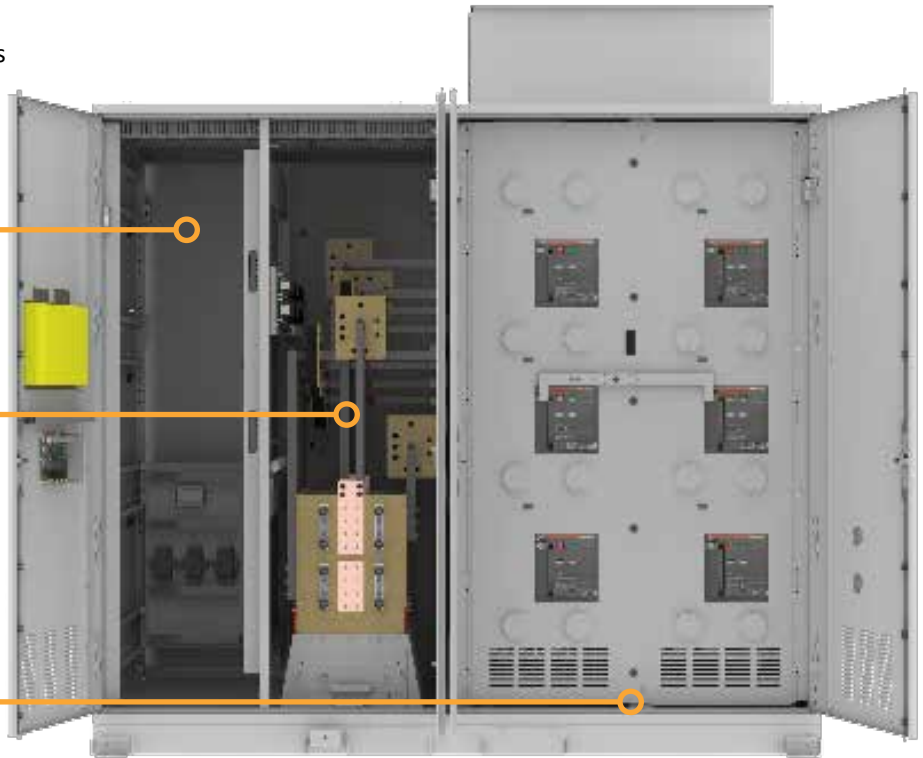

Standard Features

Every LayerZero Power Systems eSTS is equipped with a suite of standard features designed to maximize power reliability, safety, and operational efficiency. Explore the elements that make LayerZero static transfer switches the industry's preferred choice.

Reliability



Optional Triple Modular Redundancy:
Fully-independent control paths ensure no single point-of-failure.



Safe Bypass Procedure:
Mechanical bypass interlock prevents human errors during bypass procedures.



Voice Guided Bypass:
Audio-video guidance offers step-by-step instructions for operators.



Convection Cooling:
Natural cooling system is maintenance-free.



Epoxy Coated Buswork:
Eliminates potential bus-to-bus faults.



Silver Plated Terminals:
Superior conductivity for enhanced electrical performance.



Maintenance-Free Joints:
Permanent brazed joints ensure longevity.



Machined Hardware:
Constant torque throughout product life.



Optical Fiber Based Controls:
Noise and interference free controls while ensuring high voltage isolation.



Serialized Critical Board Tracking:
Active database tracking for essential boards.

Safety



INSIGHT IR® Cameras:
Monitor bolted connections for temperature anomalies.



Sectionalized Components:
Allows safe de-energization for maintenance.



Front-Only Access:
Safe installation and maintenance without side/rear access.



Dead Front Hinged Doors:
Ensures a safe work environment with no exposed live parts.

Connectivity

Ethernet Connectivity:
Secure VPN router for remote monitoring.

BACnet/Modbus/TCP:
Connect to existing systems without proprietary restrictions.

NTP Time Clock Synchronization:
Enables timeline-based event logging.

HTTP/HTTPS Web Interface (TLS 1.2+):
Meters, Alarms, Waveforms, History/Event Log, Diagnostics.

Power Quality Monitoring



Real-Time Waveform Capture:
Captures a picture of the power three-cycles before and after every event.

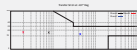

ITIC Plotting:
Analyze if equipment was affected by power quality events.



Local Touch-Screen Interface:
Secure interface for local STS operations.



Waveforms Automatically Emailed:
Send waveforms to designated individual post-transfer.

The 4-Pole eSTS Lowers Infrastructure Costs While Maintaining High Reliability

Increasingly, data center operators aspire to increase their energy efficiency, thus reducing operating costs. A popular technique deployed to achieve higher efficiency of critical operations is minimizing the number of AC power transformations between the building entrance and the eventual critical load. Facilities are being designed to step down voltage at the incoming sub-station to 277/480 V level; UPS systems are being deployed with native 4-wire, 277/480 V output. Critical loads are operated at 277 V L-N. The cost of cabling in the facility is optimized at a higher voltage; the loss of efficiency from another voltage transformation to 120/208 V is avoided.

Against this backdrop and in an environment that provides two independent sources of power, if a static transfer switch is needed to increase the reliability of power to the critical load and/or to increase the concurrent maintainability of the facility's electrical infrastructure, then the static transfer switch must be a four-pole switch. The transfer mechanism must transfer phase conductors (A, B & C) in an open transition manner while ensuring that the transfer of the neutral between adjacent sources is completed without interruption to the neutral conductor.

LayerZero's 4-pole eSTS is the most reliable, connected and information-centric product designed for this application. LayerZero uniquely uses SCR-based solid-state transfers for phases A, B, C and Neutral. Further, for operator safety, LayerZero deploys 4-pole breakers for input, output and bypass isolation.

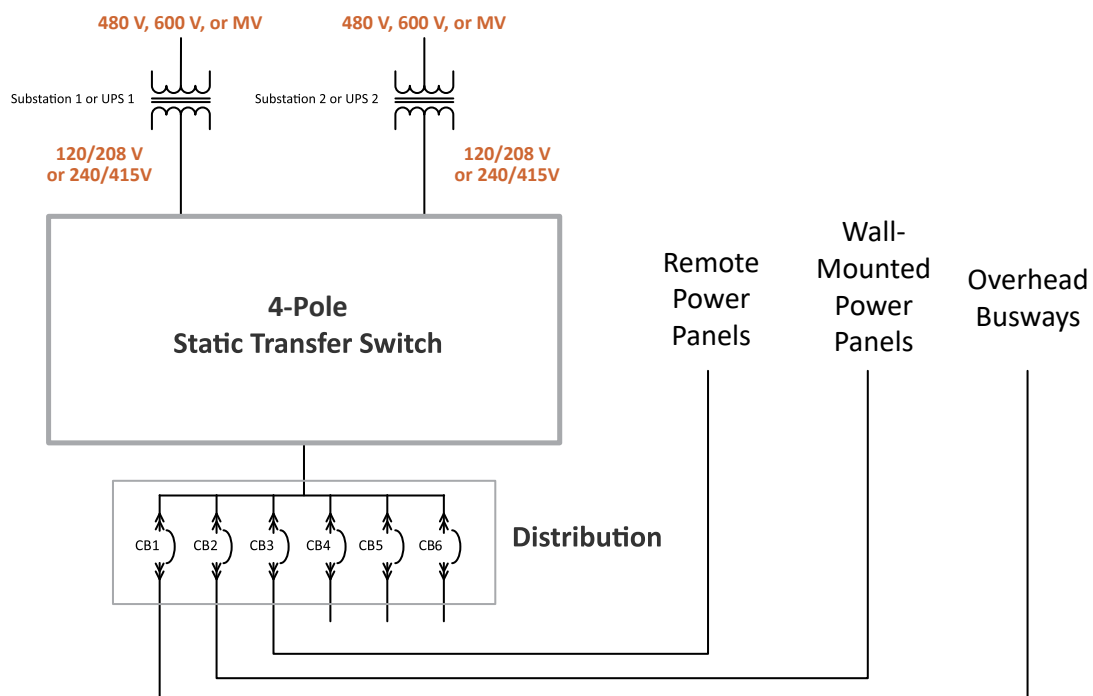

Reliability Overview

LayerZero eSTS Reliability Overview

The LayerZero eSTS Provides Many Dimensions of Reliability:

- **Control System Reliability:**
 - **SMR (Single Module Redundancy, Standard):** Our foundational system ensuring consistent and reliable operation.
 - **TMR (Triple Modular Redundancy, Optional):** LayerZero's TMR goes beyond SMR with three independent control systems. Each system operates in isolation, individually assessing and acting on voltage and current data, ensuring that, even if one control path fails, the STS can seamlessly continue its operation. This is not merely "triple-redundancy"; it's a meticulously designed system for unmatched reliability.
- **Control Power Supply Reliability:** Designed for consistent power delivery and preventing unforeseen interruptions.
- **Signal Reliability:** Designed for clear and precise signal transmission, minimizing the risk of errors.
- **Operator Procedural Reliability:** Features that prioritize intuitive, error-free operations, ensuring the system's integrity.



The Series 70: eSTS is designed for maximum reliability

Single Module Redundancy (SMR) Reliability (Standard)

Single Module Redundancy (SMR) is a cost-effective topology that delivers redundant power paths to mission-critical environments. In SMR systems, each source includes built-in triple redundancy for processors, and every phase is controlled by a dedicated gate-drive board.

The LayerZero SMR topology is uniquely fail-safe, maintaining full switching functionality even if a critical control board fails.

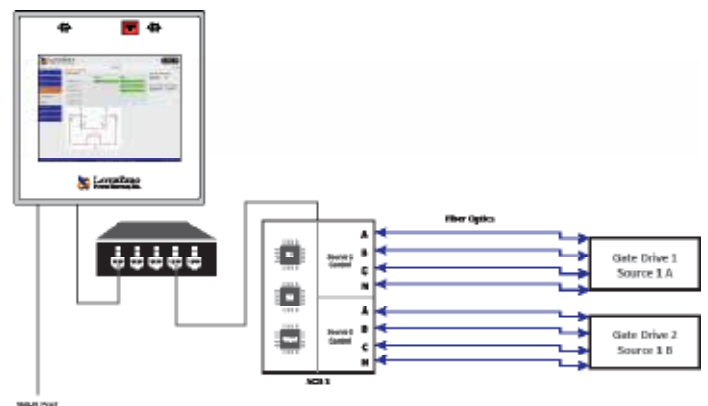

Redundant Control Paths of LayerZero SMR Gate Drives

Reliability Features: Triple Modular Redundancy (TMR) *Optional

Triple Modular Redundancy (TMR) Reliability (Optional)

LayerZero TMR has all the redundancy of SMR, plus each STS has three independent sets of analog and digital data acquisition and control systems. There is no direct communication between the systems. They do not even share a common system clock.

Each control system independently acquires voltage and current data, determines whether a source is good or bad, and makes decisions to transfer independently.

Even if an entire control path or its subcomponent fails, followed by a failure of the active power source, the STS will still complete its mission of transferring to the alternate source.

Triple Modular Redundancy is based on proven statistics and stringent mathematics. Similar-sounding terms like “tri-” or “triple-redundant” are used in the industry to describe other STS products, but these do not offer the same high level of reliability as LayerZero TMR.



Three System Control Boards (SCBs) in a TMR Configuration

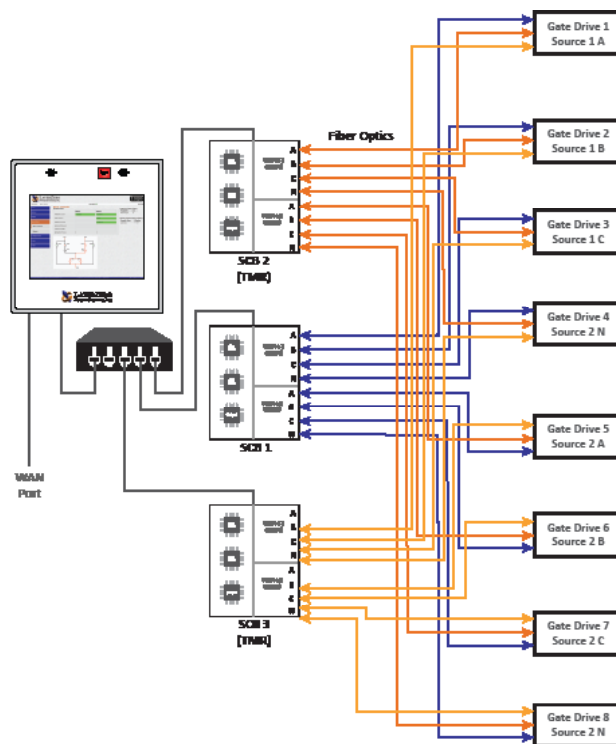

Redundant Control Paths of a TMR Configuration

Reliability Features: Single Module Redundant (SMR) Redundancy

eSTS SMR Triple Redundant Power Supply Architecture

Divided into four (4) logical failure groups:

- System controls
- Source 1 gate drives
- Source 2 gate drives
- Peripherals.

The three (3) available source of power from which to supply control power to each failure group are:

- Source 1
- Source 2
- STS Output.

LayerZero’s STS design incorporates twelve (12) power supplies (3 power sources x 4 failure groups.) The resultant control power topology utilizes all possible power paths to the four logical STS failure groups; and is the most comprehensive and redundant power supply system in existence.

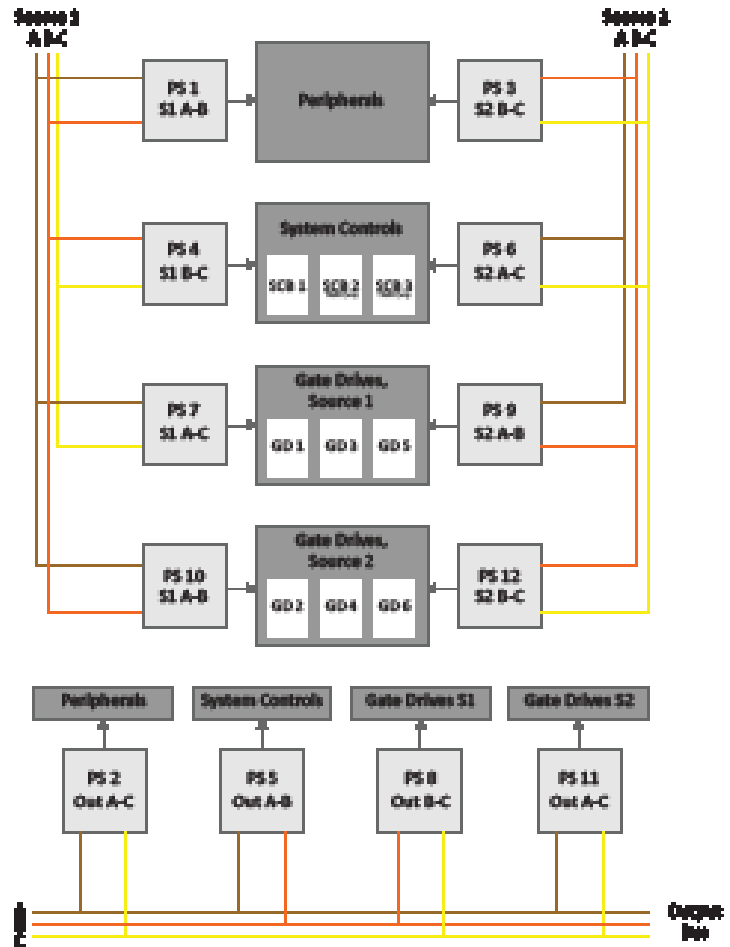

eSTS SMR Triple Redundant Processors

- Separate/independent processors for Source 1, Source 2 and Output power quality analysis.
- If Source 1 processor malfunctions then system is able to be commanded to transfer to Source 2; & vice versa.
- If main control system fails then STS continues to conduct power to the load from the existing source of power. (However STS is unable to transfer to the other source).
- Each phase of each source is controlled with a separate gate drive circuit board.

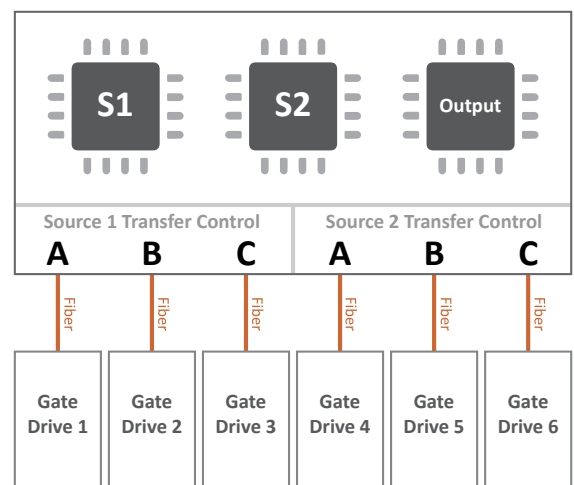

Reliability Features

Mechanical Bypass Interlock

In order to minimize the possibility of operator error during equipment bypass operations, LayerZero provides:

1. Interlocked breakers
2. Mechanisms to ensure that a source cannot be bypassed without the STS on the correct source.
3. Safeguards to make certain that sources cannot be connected to each other inadvertently.
4. A voice-prompted bypass procedure that guides the operator through the sequence.
5. A step-wise pictorial & video presentation is provided on the touch-screen display during bypass.



Mechanical Bypass Interlock "Goalpost" Design

Voice Guided Bypass

Operator error during maintenance bypass is a well-known reliability risk. To address this, LayerZero eSTS features an interactive voice-guided bypass system that leads operators through the process one step at a time. Each operation appears on its own screen, accompanied by visual and audio prompts that make it virtually impossible to perform steps out of sequence, dramatically reducing human error and improving operational safety.



The Voice Guided Bypass Screen in the LZA GUI

No Fans, Dust Filters, or Fan Fuses

The Series 70: eSTS Static Transfer Switch utilizes a natural convection-cooled heat dissipation system.

Fans and fan sensors are some of the most common components to fail. For maximum uptime, LayerZero's eSTS systems do not contain any fans, dust filters to change, or fan fuses to replace.

The heat sink arrangement is staggered between sources and phases to minimize the creation of extreme thermal gradients between heat sink columns when conducting on one source or the other.



Convection-Cooled Design in an eSTS, showing perforated vents on the cabinet bottom

Reliability Features

Epoxy Coated Buswork/Maintenance Free Joints

LayerZero's use of epoxy-coated buswork enhances both operator safety and system reliability by eliminating the potential for bus-to-bus faults. Each bus joint is permanently brazed and maintenance-free, ensuring long-term stability without the need for periodic tightening or service.

Silver Plating

To ensure the highest level of electrical performance, all bus joints and terminals are silver-plated. Silver's exceptional conductivity and low resistance deliver superior contact, minimizing losses and optimizing efficiency across all power paths.



Silver-Plated, Epoxy Coated Customer Inputs for Source 1 and Source 2

Machined Hardware

LayerZero employs precision-machined cap screws paired with engineered disc springs for every bolted connection. This combination provides a flat pressure-versus-deflection profile, maintaining constant torque and contact pressure throughout the product's life.

Tested in environments with wide temperature variations, this design ensures that once connections are tightened, they stay that way.



Machined Cap Screws and Engineered Disc Springs Utilized in LayerZero Power Systems Products

Fiber Optic Controls Increase System Reliability

LayerZero's fiber optic-based control system eliminates electrical noise and interference while electrically isolating low-voltage controls from high-voltage circuits. In the eSTS design, gate drives operating at power circuit voltage receive control signals through optical fibers, ensuring secure communication, electrical isolation, and enhanced system reliability.



Fiber Optic Connections (highlighted) in a Gate Drive

Safety - Ease of Maintenance

INSIGHT IR® Portholes Permit Scanning of Bolted Connections with Dead-Front Doors Closed

Strategically positioned IR-scan portholes to enable safe thermal scanning of all bolted connections with the deadfront closed, without exposing the operator to power circuit voltage. Thermal scans can be done from the front – without ever having to open the dead-front door.

The IR window swivels upward and unlocks with key-hole access to reveal a mesh, allowing the operator to point-and-shoot thermal cameras to obtain readings.

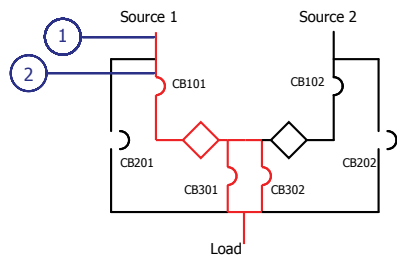

INSIGHT IR® Porthole mounted on a polycarbonate window.

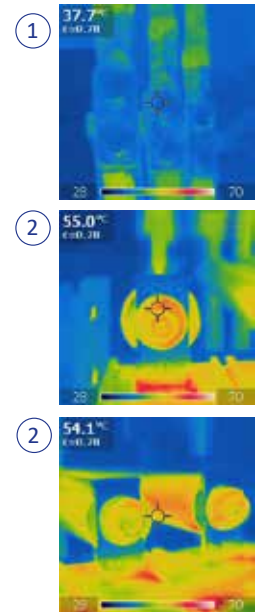

An IR Camera Scanning an INSIGHT IR® Porthole for Source 1 Input (Door and side panel hidden for visibility)

INSIGHT IR® Cameras Provide Early Detection

INSIGHT IR® is a thermal monitoring system that is designed to continuously monitor the temperatures of critical components. INSIGHT IR® captures data from a network of fixed infrared cameras, and displays a live image of the temperature of each connection. INSIGHT IR® has the capability to view temperatures by-phase. If a problematic area is detected early, repairs can be made on equipment before the problem leads to downtime.



INSIGHT IR® Camera Housing



INSIGHT IR® live images can be viewed on a local or remote display.

INSIGHT IR® Cameras are installed near bolted connections and critical components, and generates a hybrid heat map over a visible image

Safety

Sectionalization Maximizes Operator Safety

Early data center electrical systems often exposed operators to live components during maintenance, increasing the risk of arc flashes, errors, and downtime. Routine tasks like operating breakers or inspecting electronics required working on energized equipment.

LayerZero's Series 70, inspired by NFPA 70E safety standards, introduced a sectionalized design that separates operator interfaces from power and control electronics. This allows safe maintenance by bypassing power around the section being serviced, reducing exposure to live parts, and supporting safer, more reliable operations.

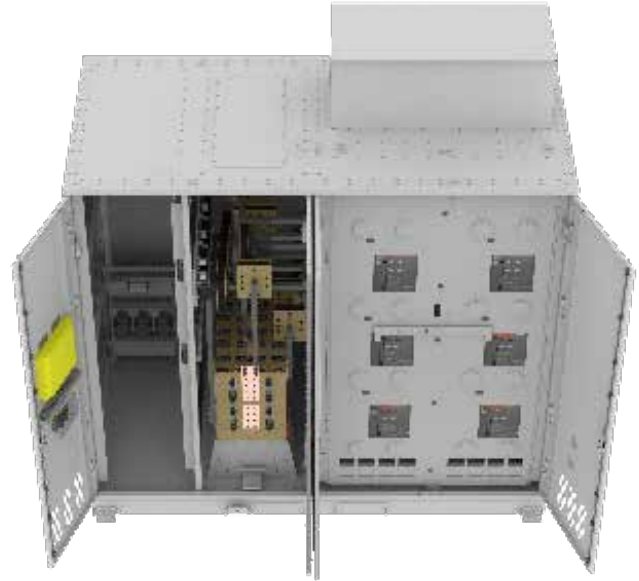

eSTS with the Outer Doors Open, showing physical separation between the power electronics and control sections

View Status LEDs and Distribution CB Positions With Dead-Front Doors Closed

LayerZero's Series 70 also solved a key safety issue in early systems: the need to open energized compartments just to check system status. In Series 70, diagnostic LEDs are visible without accessing live areas, thanks to its dead-front design.

This improves safety, simplifies inspections, and enhances overall system reliability.



Visibility of status LEDs.

Ease of Maintenance/Connectivity Options

Front Only Access Saves Space

The Series 70 eSTS is designed to be installed, operated, diagnosed, and maintained entirely from the front. The dead-front panels are hinged, eliminating the need to remove side or rear covers.

Unhinged covers can be bulky and unwieldy, and operator error during the removal and replacement of covers has been known to cause mishaps and compromise load reliability. A safe, non-invasive operation and maintenance regime results in a high reliability of the critical load.

The Series 70 eSTS utilizes dead-front hinged doors, and an alarm notifies when an outer door has been opened.



Front of the eSTS Static Transfer Switch

eSTS Connectivity Options

- Non-Proprietary Protocols

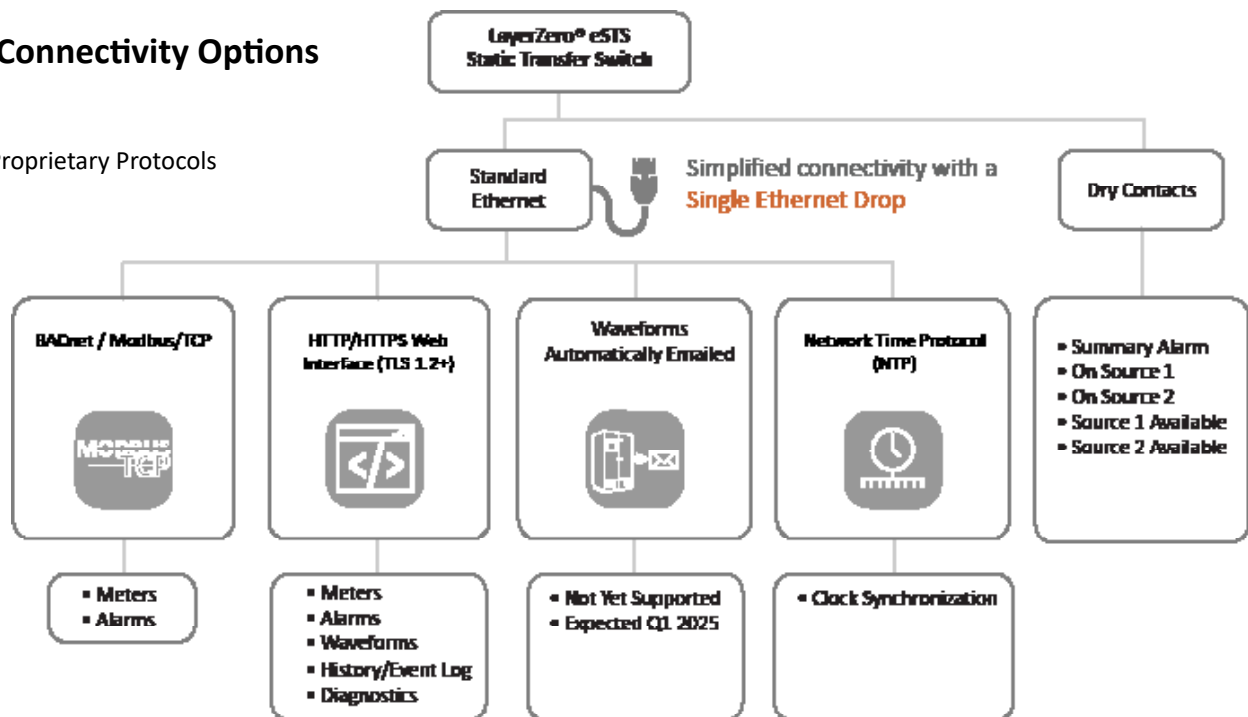

Generate Easy-To-Understand Power Quality Reports with ITIC Plotting

All LayerZero Power Systems products have on-board power quality analyzers that break down power sources into samples. If the power quality goes out of specification on a source, eSTS will transfer to the alternate source, automatically generating waveform captures and VDAT-generated ITIC curves of the event. This data is remotely accessible by connecting to the unit via web browser.

VDAT (Voltage Disruption Analysis Tool) is a quantum leap in the field of power systems data interpretation. By harnessing state-of-the-art algorithms and processing techniques, VDAT effortlessly translates complex power data into discernible, actionable insights. VDAT tackles a major industry challenge: while traditional waveform captures are often intricate and challenging to interpret, VDAT brings clarity with its intuitively designed plots based on Information Technology Industry Council (ITIC) standards, empowering professionals to make quick and informed decisions.

In the test below, the STS was connected to two sources 150 degrees out-of-phase. Source 2 breaker was opened, causing the STS to perform an automatic transfer to the primary source. A delayed transfer occurred, causing events on Phases A, B, and C, automatically generating ITIC plots. Unlike waveform captures, ITIC plots are easy-to-read, and do not require expert analysis to understand.

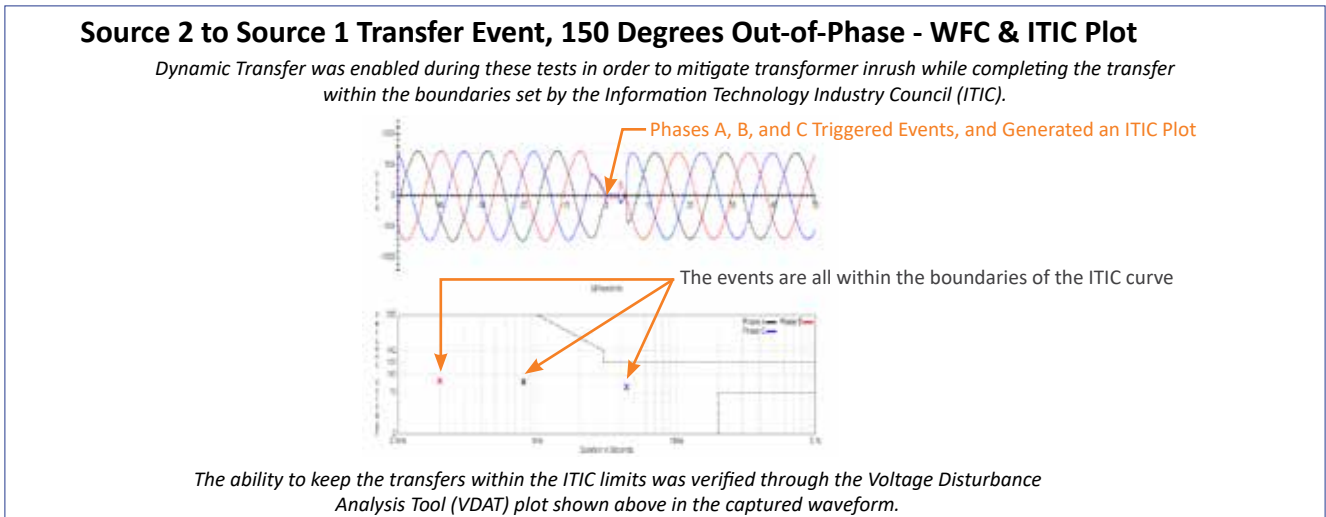
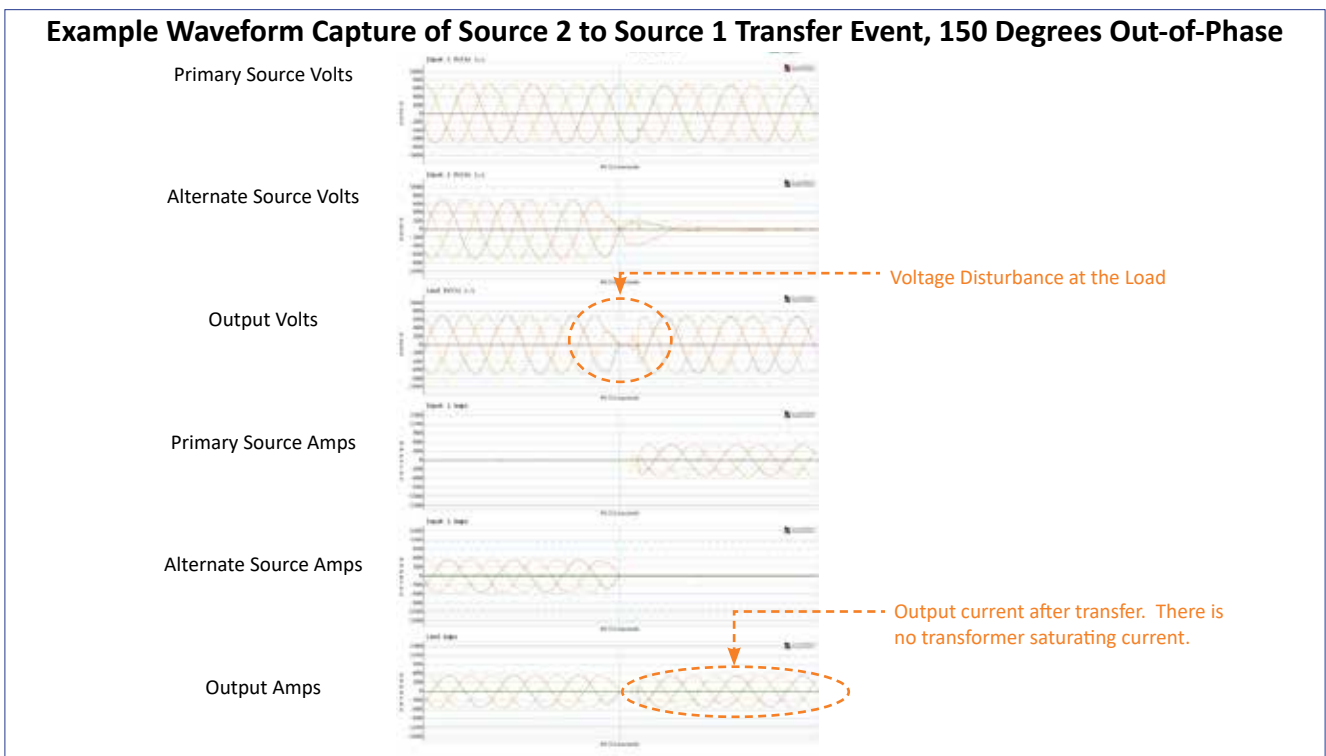

Features/Power Quality Monitoring

LayerZero Power Quality Monitoring

LayerZero PQM (Power Quality Monitoring) allows you to be aware of all activity in your critical power distribution systems, it is an all encompassing monitoring system with local and remote communications options. From basic monitoring, alarms, to advanced power quality monitoring functionality, LayerZero PQM provides a wide-range of options to help you maintain the highest level of reliability.

LayerZero PQM gives you a vendor-neutral “Birds Eye” view of your entire critical power distribution infrastructure. LayerZero PQM maximizes reliability, letting you know if a source has quality issues, if a UPS output is bad, or if there are any alarms. In addition, LayerZero PQM empowers users with the capability to go back in time to retrace the exact sequence of historical events. No other tool in the mission-critical industry empowers users with this robust capability.

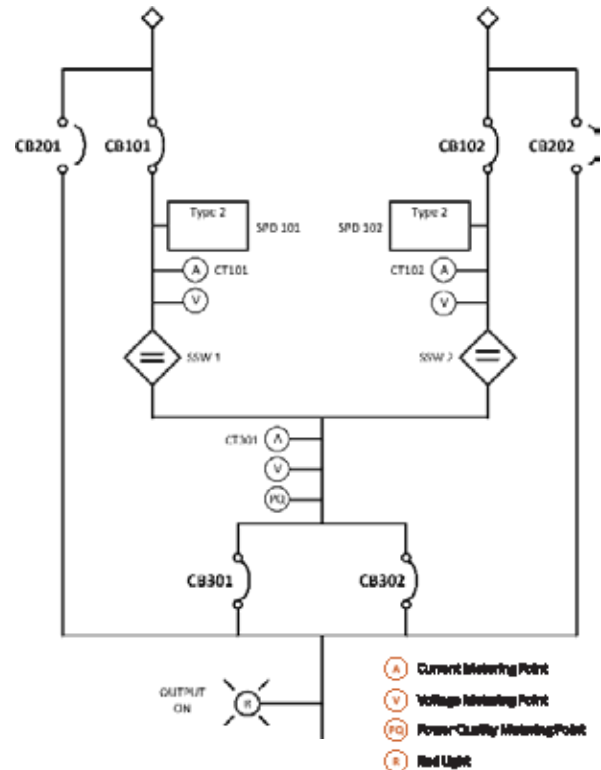

15" Color Touch Screen (Standard)

1. Stereo Speakers for Guided Bypass Prompts
2. Output On Light (Remains Lit in Bypass Isolate Mode)
3. Alarm & Bypass Indicator
4. SCB Status Indicator
5. Logged In User
6. Navigation Menu
7. Customer & Project Information
8. Date & Time

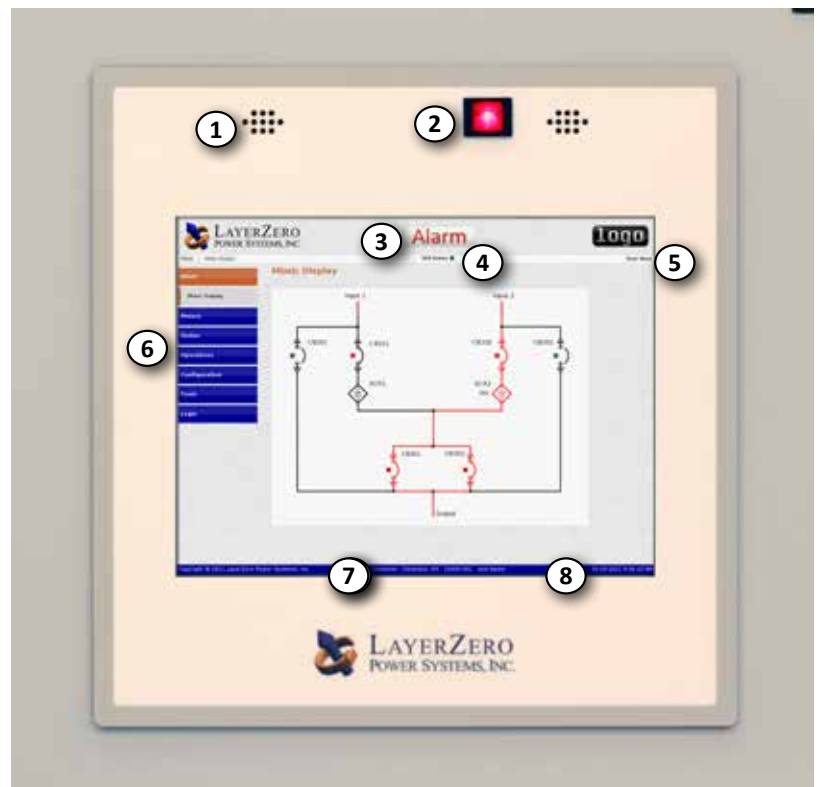

Power Quality Monitoring

Static Switch Power Quality Monitoring

The Series 70: 1600 A 4-Pole eSTS is equipped with LayerZero SSQM (Static Switch Quality Monitoring), an all encompassing monitoring system with local and remote communications options.

From basic monitoring & alarm reporting, to advanced power quality monitoring functionality, LayerZero’s SSQM provides a wide-range of options to help you be aware, be vigilant, be proactive in your quest to create a safe, stable and reliable operation.



eSTS Touch Screen GUI showing Real Time Waveform Capture

LayerZero’s SSQM Provides Answers

LayerZero SSQM provides timestamped pictures of waveforms before and after events, providing information that enables facilities to go back in time to methodically identify and correct the root causes of events. LayerZero actively captures power quality information at the STS, PDU, and RPP - permitting thorough post-event analysis.

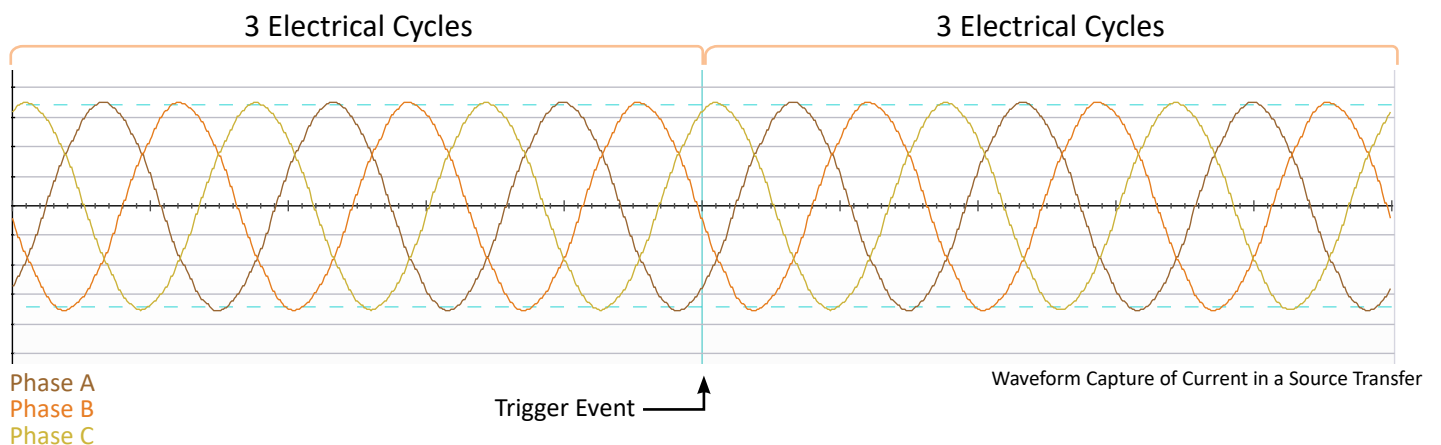

LayerZero SSQM Technical Specifications

LayerZero SSQM Parameters		Mains
Voltage Inputs and Output	Voltage (Volts)	✓
	Voltage Average of Phases (Volts)	✓
	Frequency (Hertz)	✓
	Total Harmonic Distortion (Percent VTHD)	✓
	Phase Rotation	✓
Current Inputs	Current (Amps)	✓
	Current Average of Phases (Amps)	✓
	Current Imbalance (Percent)	✓
	Real Power (kilowatts)	✓
	Apparent Power (kilovolt-amperes)	✓
	Reactive Power (kilovolt-amperes reactive)	✓
	Power Factor	✓
	Crest Factor	✓
	Crest Factor Average of Phases	✓
	Phase Difference Between Sources	✓
	Phase Difference Between Sources and Output	✓
Alarms	Summary Alarm	✓
	On Source (1/2/3)	✓
	Source Fail (1/2/3)	✓
	Source Preferred (1/2/3)	✓
	Source 1st Alternate (1/2/3)	✓
	Source Over/Under Voltage (1/2/3)	✓
	Source Over/Under Frequency (1/2/3)	✓
	Source Not Available (1/2/3)	✓
	Output Failure	✓
	Source Overcurrent (1/2/3)	✓
	Source Exceeds Manual Limit (1/2/3)	✓
	Source Exceeds Automatic Limit (1/2/3)	✓
	Bypassed to Source (1/2/3)	✓

Technical Specifications: 4-Pole Static Transfer Switch

Mechanical Characteristics *	
Current/Voltage/Number of Poles	1600 A 277/480 V 4-Pole
Heat Dissipation	28,500 Btu/Hr
Weight	5,600 lbs (2540 kg)
Dimensions	108" x 114" x 55.5" (2734mm x 2895mm x 1410mm)
Clearances	Front: 42" (1067mm) Rear: 42" (1067 mm) Sides: 0" Top: 18" (457mm)
Frame Construction	Welded Frame
Electrical Connections	Silver-Plated Solid Busbar
Color	Textured Powder Coat White (RAL 7035), Blue (RAL 5017), Black, Custom
Floor Stands	Optional
Seismic floor stands	Optional
Junction Boxes	Optional
Sectionalization	Engineered Composite Insulation, Dead Front Doors
Electrical Characteristics	
Number of Inputs	2, 3 (3 optional)
Number of Output CBs	1, 2
Frequency	50 Hz, 60 Hz
Poles	4-pole
Phases	3 Phase, 3 Wire, 4 Wire + Ground
Neutral Rating	100%, 150%, 200%
Transfer Time	Nominal 1/4- cycle for in-phase sources
Redundancy	Single Module Redundancy, Triple Modular Redundancy (Optional)
Circuit Breaker Type	Molded Case Switch (Standard), Electronic Trip (Optional)
Circuit Breaker Mounting Type	Fixed
TVSS	Standard
Power Quality Monitoring	
Power Quality Monitoring Technology	LayerZero Power Quality Monitoring
Waveform Capture	Local Display, Remote Display via Web Browser, Waveforms Automatically Emailed
Voltmeter	Input sources and Output, for each phase
Ammeter	Input sources and Output, for each phase
Frequency Meter	Both Sources
Synchroscope	Phase Angle Meter Between Sources
Metering	Apparent Power, Real Power, Power Factor, Output Total Harmonic Distortion
Time Stamped Transfer Count	From First Day Use, From Last Reset
CB Status Indicator	Open/Closed/Tripped Circuit Breaker
Source Indicator	Preferred Source
Power Path Indicator	On Live Mimic

*Dimensional & weight data is only valid for 2-source.

All product specifications are subject to change without notice.

Technical Specifications

Operational Characteristics	
Transfer Modes	Automatic; Manual (via Preferred Source Selection)
Inrush Mitigation Technology	Patented Dynamic Phase Compensation Algorithm (U.S. Patent 7,589,438 B2)
Cooling	Convection Cooling
Cable Access	Top/Bottom
Service Access	Front Only
Bypass Interlock Mechanism	Mechanical
Noise & Interference Isolation	Optical Fiber in Critical Control Paths
IR Scan Port Type	INSIGHT IR® IR Portholes
SCR Type	Puck
Display Type	15" Color Touch Screen
Display Resolution	1024x768
Bypass Assistance	Voice-Guided Bypass
Audio	Bezel-Mounted Stereo Speakers
Languages	English, French
Mimic Panel	Digital
Setpoints Control	Digital
Power Supplies	Redundant (4 Failure Groups. Triple Redundant Supplies. 12 Power Supplies Provided.)
Connectivity	
Meters	Local Display, Ethernet, BACnet/Modbus/TCP, HTTP/HTTPS Web Interface (TLS 1.2+)
Alarms	Local Display, Ethernet, BACnet/Modbus/TCP, HTTP/HTTPS Web Interface (TLS 1.2+)
Summary Alarm	Dry Contacts; Local Display; BACnet/Modbus/TCP; Web Browser
Waveforms	Local Display, Ethernet, HTTP/HTTPS Web Interface (TLS 1.2+)
History/Event Log	Local Display, Ethernet, HTTP/HTTPS Web Interface (TLS 1.2+)
Diagnostics	Local Display, Ethernet, HTTP/HTTPS Web Interface (TLS 1.2+)
Time Synchronization	Network Time Protocol (NTP)
Standards Conformance	
CSA	ETL Listed to C22.22 No 107.
UL	ETL Listed to UL 1008S

All data tables above are for 4-pole only. Contact LayerZero for custom sizes and designs.

All product specifications are subject to change without notice.



LAYERZERO

POWER SYSTEMS, LLC.

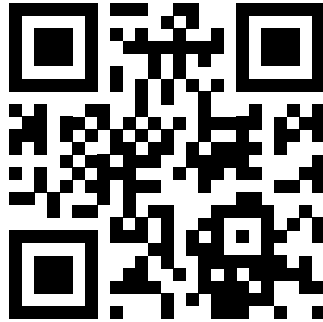

Contact Info

Phone: (440) 399-9000

Emergency Phone: 1-844-855-LZPS (5977)

Email: info@layerzero.com

www.LayerZero.com

Headquarters

1500 Danner Drive
Aurora, OH 44202 U.S.A.

Auxiliary Assembly Plant

350 Harris Drive
Aurora, OH 44202 U.S.A.

Auxiliary Assembly Plant II

10030 Philipp Pkwy
Streetsboro, OH 44241 U.S.A.

[LayerZero](#)®, INSIGHT IR®, SAFEARM®, SAFEPANEL®, and LayerZero Power Systems, LLC.® are registered trademarks of LayerZero Power Systems, LLC. All Rights Reserved.

All product specifications are subject to change without notice.

Rev. 4/26 #9