



LAYERZERO
POWER SYSTEMS, LLC.

The Foundation Layer

Series 70: eSTS

400 A 480 V 3-Pole Static Transfer Switch



Product Brochure

The LayerZero eSTS Static Transfer Switch Maximizes Power Reliability

eSTS Automatically Transfers Between Two or Three* Power Sources

LayerZero Power Systems designs and manufactures the world's **most reliable** static transfer switch. The Series 70 eSTS is a solid-state transfer switch that automatically or manually performs transfers between two in-phase AC sources within a quarter cycle. Transfers are open-transition, ensuring that the connected load experiences minimal disruption without ever cross-connecting the power sources. One power source is designated as the preferred source. If the preferred source fails, the load is automatically and seamlessly transferred to the alternate source via open-transition static transfer. For emergency transfers between asynchronous sources, dynamically phase-compensated transfers help minimize saturation of downstream transformers in 3-phase, 3-wire eSTS configurations.

*Optional

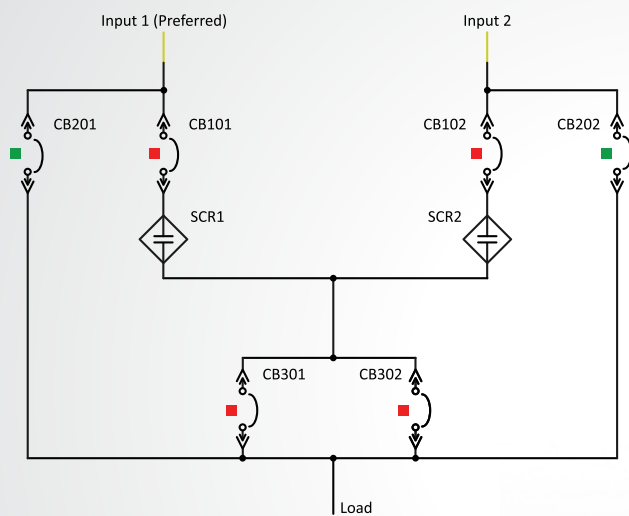

eSTS Static Transfer Switch One Line Diagram



Controls Section Contains:

- Power electronics
 - SCRs (Silicon Control Rectifier) in Convection Cooled Heat Sinks
- Control Electronics
 - System Control & Data Acquisition Boards
 - SCR Gate Drives
 - Redundant Power Supply System
 - I/O system; VPN Router

CB Section Contains:

- Input isolation switches
- Bypass isolation Switches
- Output isolation switches
- Source connection terminals
- Load connection terminals

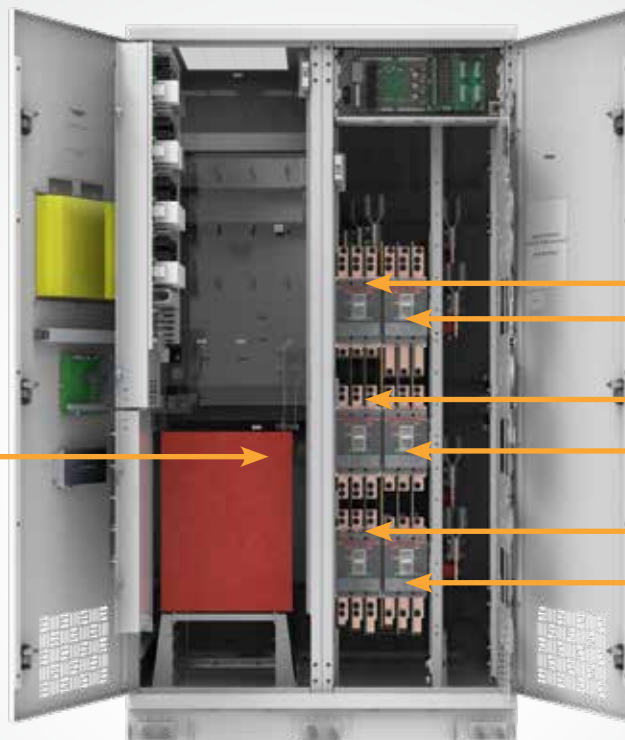
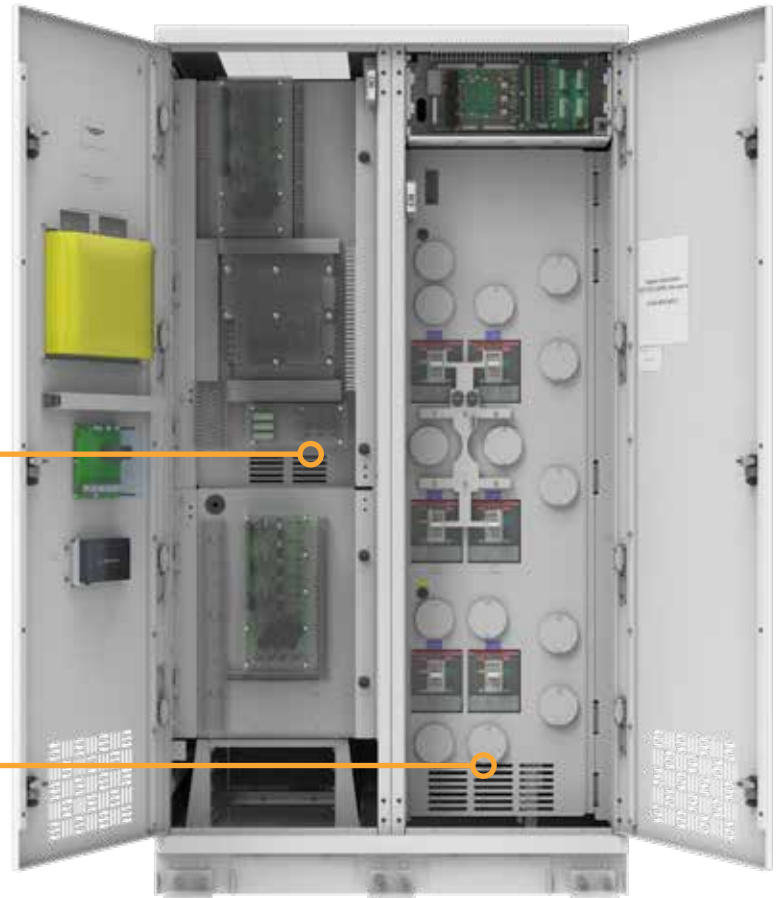

SCRs and Heat Sink

- CB101 Source 1 Isolate
- CB102 Source 2 Isolate
- CB201 Bypass Isolate, Source 1
- CB202 Bypass Isolate, Source 2
- CB301 Output Isolate 1
- CB302 Output Isolate 2, (Redundant, Optional)

Standard Features

Every LayerZero Power Systems eSTS is equipped with a suite of standard features designed to maximize power reliability, safety, and operational efficiency. Explore the elements that make LayerZero static transfer switches the industry's preferred choice.

Reliability



Optional Triple Modular Redundancy:
Fully-independent control paths ensure no single point-of-failure.



Safe Bypass Procedure:
Mechanical bypass interlock prevents human errors during bypass procedures.



Voice Guided Bypass:
Audio-video guidance offers step-by-step instructions for operators.



Convection Cooling:
Natural cooling system is maintenance-free.



Epoxy Coated Buswork:
Eliminates potential bus-to-bus faults.



Silver Plated Terminals:
Superior conductivity for enhanced electrical performance.



Maintenance-Free Joints:
Permanent brazed joints ensure longevity.



Machined Hardware:
Constant torque throughout product life.



Optical Fiber Based Controls:
Noise and interference free controls while ensuring high voltage isolation.



Serialized Critical Board Tracking:
Active database tracking for essential boards.

Safety



INSIGHT IR® Cameras:
Monitor bolted connections for temperature anomalies.



Sectionalized Components:
Allows safe de-energization for maintenance.



Polycarbonate Windows:
View critical board LEDs with closed dead-front door.



Front-Only Access:
Safe installation and maintenance without side/rear access.



Dead Front Hinged Doors:
Ensures a safe work environment with no exposed live parts.

Connectivity

Ethernet Connectivity:
Secure VPN router for remote monitoring.

Modbus/TCP:
Connect to existing systems without proprietary restrictions.

NTP Time Clock Synchronization:
Enables timeline-based event logging.

SNMP Connectivity:
Remote management via SNMP.

Power Quality Monitoring



Real-Time Waveform Capture:
Captures a picture of the power three-cycles before and after every event.

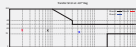

ITIC Plotting:
Analyze if equipment was affected by power quality events.



Local Touch-Screen Interface:
Secure interface for local STS operations.



Waveforms Automatically Emailed:
Send waveforms to designated individuals post-transfer.

Reliability Overview

LayerZero eSTS Reliability Overview

The LayerZero eSTS Provides Many Dimensions of Reliability:

- **Control System Reliability:**
 - **SMR (Single Module Redundancy, Standard):** Our foundational system ensuring consistent and reliable operation.
 - **TMR (Triple Modular Redundancy, Optional):** LayerZero’s TMR goes beyond SMR with three independent control systems. Each system operates in isolation, which individually assess and act on voltage and current data, ensuring that even if one control path fails, the STS can seamlessly continue its operation. This is not merely “triple-redundancy”; it’s a meticulously designed system for unmatched reliability.
- **Control Power Supply Reliability:** Designed for consistent power delivery and preventing unforeseen interruptions.
- **Signal Reliability:** Designed for clear and precise signal transmission, minimizing the risk of errors.
- **Operator Procedural Reliability:** Features that prioritize intuitive, error-free operations, ensuring the system’s integrity.



The Series 70: eSTS is designed for maximum reliability

Single Module Redundancy (SMR) Reliability (Standard)

Single Module Redundancy is a cost-effective topology that delivers redundant power paths to mission-critical equipment. In SMR systems, each source features built-in triple processor redundancy.

Additionally, every phase is independently controlled by its own gate drive board.

What sets LayerZero’s Single Module Redundant topology apart is its fail-safe design, maintaining full switching functionality even in the rare event of a critical board failure.

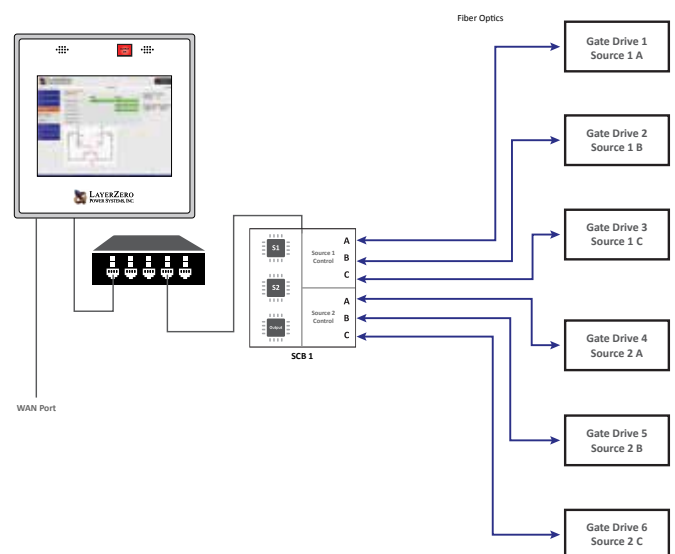

Redundant Control Paths of LayerZero SMR Gate Drives

Reliability Features: Triple Modular Redundancy (TMR) *Optional

Triple Modular Redundancy (TMR) Reliability (Optional)

LayerZero TMR includes all the redundancy features of SMR, with the added benefit of three fully independent analog and digital data acquisition and control systems. These systems do not share communication paths or even a common system clock.

Each control system independently gathers voltage and current data, evaluates source quality, and makes autonomous transfer decisions.

Even if one entire control path - or its subcomponents - fails, followed by a failure of the active power source, the STS remains capable of transferring to the alternate source.

LayerZero’s Triple Modular Redundancy is grounded in rigorous statistical modeling and mathematical validation. While other STS products may use terms like “tri-” or “triple-redundant,” they do not match the level of reliability provided by LayerZero TMR.



Three System Control Boards (SCBs) in a TMR Configuration

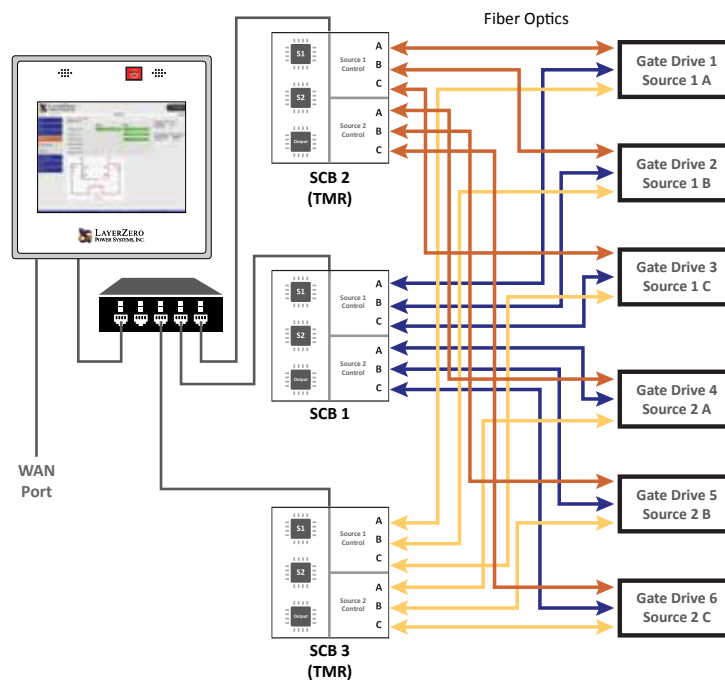

Redundant Control Paths of a TMR Configuration

Reliability Features: Single Module Redundant (SMR) Redundancy

eSTS SMR Triple Redundant Power Supply Architecture

Divided into four (4) logical failure groups:

- System controls
- Source 1 gate drives
- Source 2 gate drives
- Peripherals.

The three (3) available source of power from which to supply control power to each failure group are:

- Source 1
- Source 2
- STS Output.

LayerZero’s STS design incorporates twelve (12) power supplies (3 power sources x 4 failure groups.) The resultant control power topology utilizes all possible power paths to the four logical STS failure groups; and is the most comprehensive and redundant power supply system in existence.

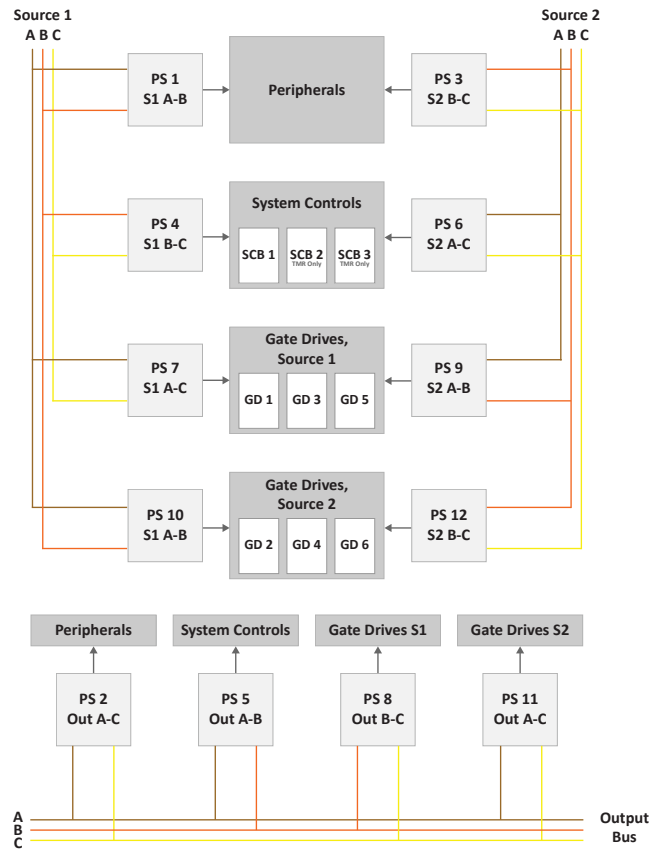

eSTS SMR Triple Redundant Processors

- Independent processors handle power quality analysis for Source 1, Source 2, and Output.
- If the processor for Source 1 malfunctions, the system can still be commanded to transfer to Source 2 - and vice versa.
- In the event of a main control system failure, the STS will continue delivering power from the current source, though it will be unable to transfer to the alternate source.
- Each phase of each source is managed by a dedicated gate drive circuit board.

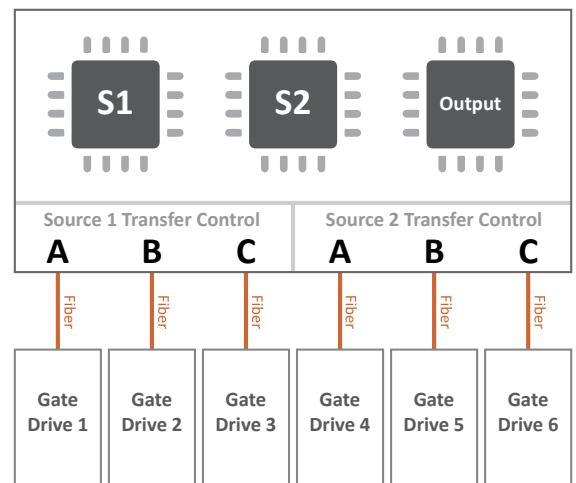

Reliability Features

Mechanical Bypass Interlock

In order to minimize the possibility of operator error during equipment bypass operations, LayerZero provides:

1. Interlocked breakers
2. Mechanisms to ensure that a source cannot be bypassed without the STS on the correct source.
3. Safeguards to make certain that sources cannot be connected to each other inadvertently.
4. A voice-prompted bypass procedure that guides the operator through the sequence.
5. A step-wise pictorial & video presentation is provided on the touch-screen display during bypass.

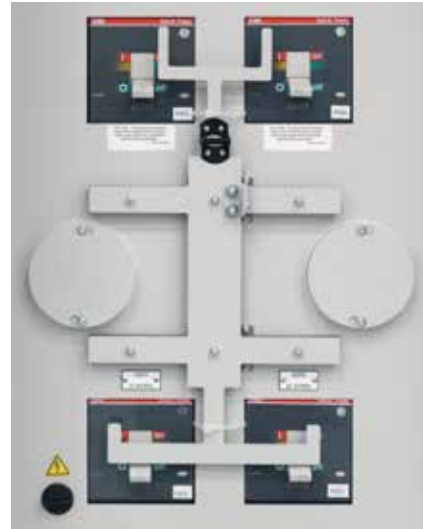

Mechanical Bypass Interlock "Goalpost" Design

Voice Guided Bypass

Operator error during maintenance bypass can pose a serious reliability risk. To mitigate this, LayerZero systems feature a voice-prompted bypass procedure that guides users through the process step by step, with only one operation displayed per screen. Visual and audio cues clearly communicate each stage of the sequence, helping to ensure the procedure is followed correctly and reducing the likelihood of operator error.



The Voice Guided Bypass Screen in the LZA GUI

No Fans, Dust Filters, or Fan Fuses

The Series 70 eSTS uses a natural convection-cooled heat dissipation system.

Since fans and fan sensors are common points of failure, LayerZero's eSTS eliminates these components. There are no fans, dust filters, or fan fuses to maintain or replace, maximizing uptime.

The heat sink arrangement is staggered between sources and phases to reduce extreme thermal gradients between heat sink columns during operation on either power source.



Convection-Cooled Design in an eSTS, showing perforated vents on the cabinet bottom

Reliability Features

Epoxy Coated Buswork/Maintenance Free Joints

Our usage of epoxy coated buswork helps ensure safety, and makes the system inherently more reliable by eliminating the possibility of bus-to-bus faults. Bus joints are permanently brazed and maintenance-free.

Silver Plating

All bus joints and terminals are silver-plated for superior performance. Silver's high conductivity and low resistance ensure optimal contact and minimal energy loss.



Silver-Plated, Epoxy Coated Customer Inputs for Source 1 and Source 2

Machined Hardware

Our bolted connections utilize machined cap screws and engineered disc springs. The result is a flat pressure vs deflection profile to ensure that all bolted connections maintain constant torque through the life of the product.

These technologies have been well tested in disparate environments of wide temperature ranges to help ensure that, once connections have been tightened, they stay that way.



Machined Cap Screws and Engineered Disc Springs Utilized in LayerZero Power Systems Products

Fiber Optic Controls Increase System Reliability

Fiber-optic controls eliminate electrical noise and interference while isolating components from high voltage. In the eSTS design, gate drives at power circuit voltage receive control signals via optical fibers, ensuring reliable operation and added protection.



Fiber Optic Connections (highlighted) in a Gate Drive

Safety - Ease of Maintenance

INSIGHT IR® Portholes Permit Scanning of Bolted Connections with Dead-Front Doors Closed

Strategically placed IR-scan portholes allow safe thermal scanning of all bolted connections with the dead-front door closed, eliminating operator exposure to power circuit voltage. Scans can be performed entirely from the front of the unit, without opening the dead-front.

The IR window swivels upward and unlocks with keyhole access, revealing a protective mesh. This design enables operators to safely point-and-shoot thermal cameras to capture accurate readings.



INSIGHT IR® Porthole mounted on a polycarbonate window.

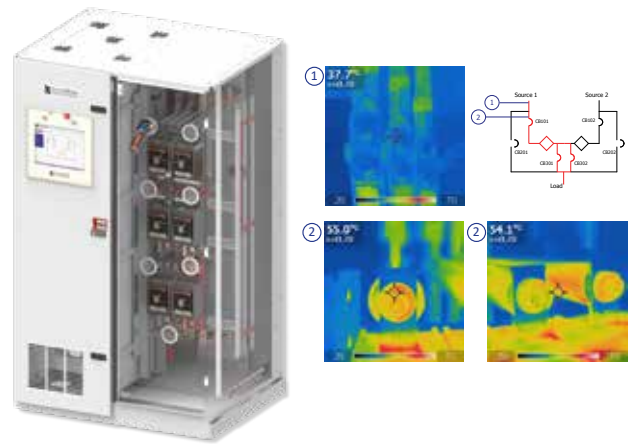

An IR Camera Scanning an INSIGHT IR Porthole for Source 1 Input (Door and side panel hidden for visibility)

INSIGHT IR® Cameras Provide Early Detection

INSIGHT IR® is a continuous thermal monitoring system designed to detect abnormal heat conditions before they become failures. A network of fixed infrared cameras provide real-time temperature images of critical connections, with visibility by phase. By identifying hot spots early, maintenance teams can take corrective action before issues escalate into costly downtime.



INSIGHT IR® live images can be viewed on a local or remote display.



INSIGHT IR® Camera Housing



INSIGHT IR® Cameras are installed near bolted connections and critical components, and generates a hybrid heat map over a visible image

Safety

Sectionalization Maximizes Operator Safety

LayerZero eSTS systems are designed with a sectionalized design to protect operators from exposed connections. Normal operator areas (breakers and switches) are physically isolated from the power electronics and control electronics sections, allowing maintenance to be performed safely. When service is required, power can be bypassed to another section so repairs can be completed without risk.



eSTS with the Outer Doors Open, showing physical separation between the power electronics and control sections

View Status LEDs and Distribution CB Positions With Dead-Front Doors Closed

The Series 70 product line was inspired by NFPA-70E, with the goal of helping data centers significantly reduce electrical safety risks. Operators can view diagnostic status LEDs and SafePanel circuit breaker positions without opening the dead-front door, maintaining full visibility while eliminating exposure to energized components.



Polycarbonate Window on the Power Electronics Section, allowing visibility of status LEDs.

Ease of Maintenance/Connectivity Options

Front Only Access Saves Space

The Series 70: A eSTS is designed to be installed, operated, diagnosed and maintained only from the front. The dead-front panels are hinged, and side or rear covers never have to be removed.

Unhinged covers can be bulky and unwieldy, and operator error during removal and replacement of covers has been known to cause mishaps and compromise load reliability. A safe, non-invasive operation and maintenance regime results in a higher reliability of the critical load.

The Series 70: eSTS utilizes dead-front hinged doors. An alarm notifies when an outer door has been opened.



Front of the eSTS Static Transfer Switch

eSTS Connectivity Options

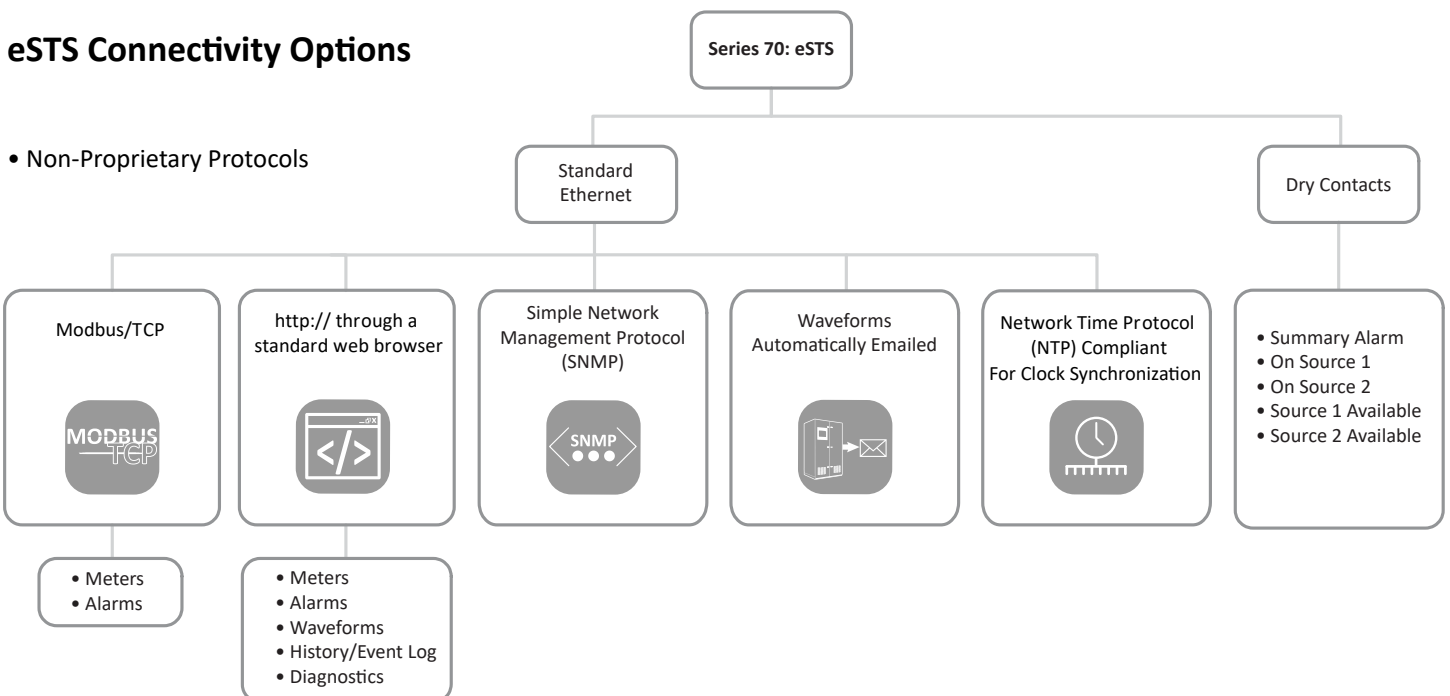

Features/Power Quality Monitoring

LayerZero Power Quality Monitoring

LayerZero PQM (Power Quality Monitoring) allows you to be aware of all activity in your critical power distribution systems, it is an all encompassing monitoring system with local and remote communications options. From basic monitoring, alarms, to advanced power quality monitoring functionality, LayerZero PQM provides a wide-range of options to help you maintain the highest level of reliability.

LayerZero PQM gives you a vendor-neutral “Birds Eye” view of your entire critical power distribution infrastructure. LayerZero PQM maximizes reliability, letting you know if a source has quality issues, if a UPS output is bad, or if there are any alarms. In addition, LayerZero PQM empowers users with the capability to go back in time to retrace the exact sequence of historical events. No other tool in the mission-critical industry empowers users with this robust capability.

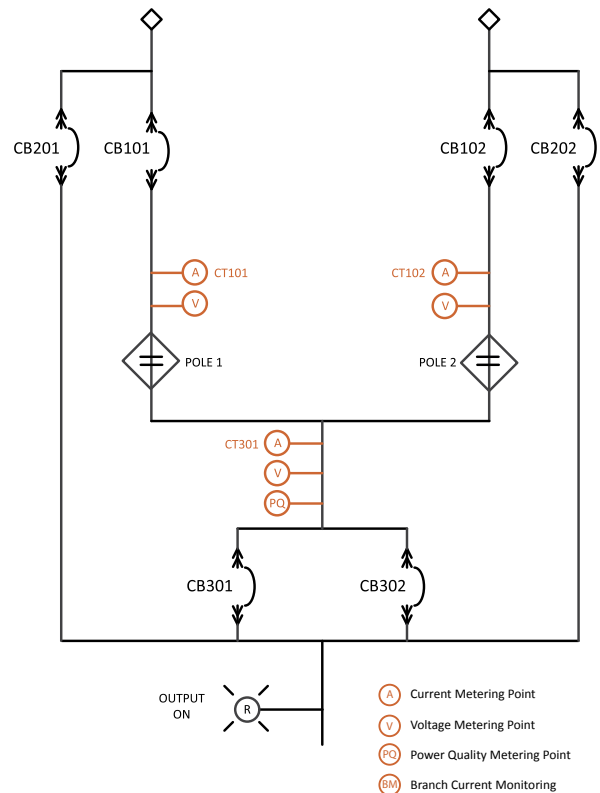

15" Color Touch Screen (Standard)

1. Stereo Speakers for Guided Bypass Prompts
2. Output On Light (Remains Lit in Bypass Isolate Mode)
3. Alarm & Bypass Indicator
4. SCB Status Indicator
5. Logged In User
6. Navigation Menu
7. Customer & Project Information
8. Date & Time

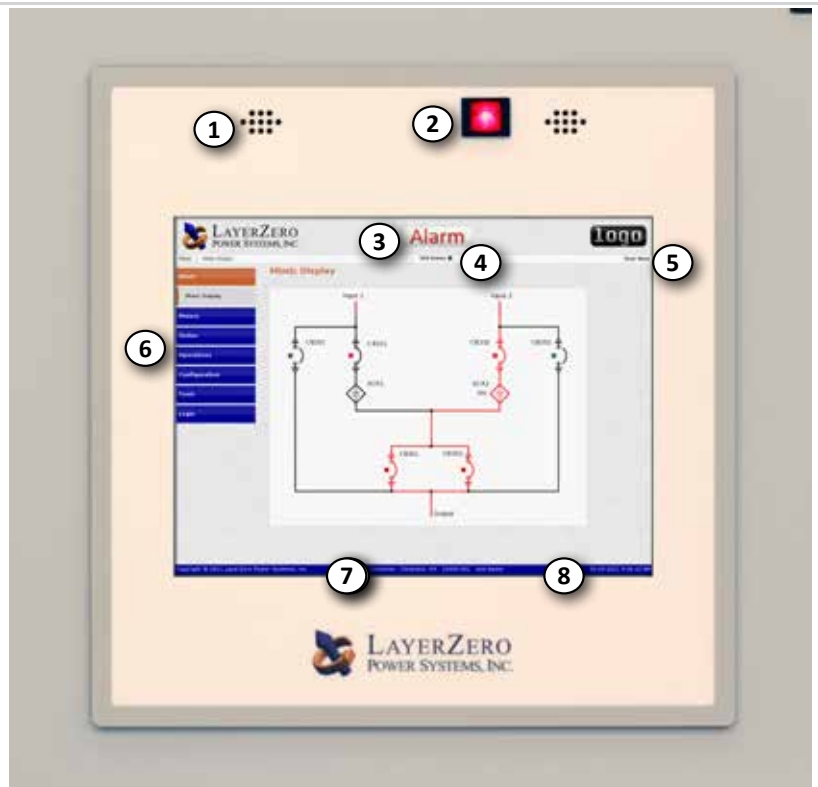

Generate Easy-To-Understand Power Quality Reports with ITIC Plotting

All LayerZero Power Systems products have on-board power quality analyzers that break down power sources into samples. If the power quality goes out of specification on a source, eSTS will transfer to the alternate source, automatically generating waveform captures and VDAT-generated ITIC curves of the event. This data is remotely accessible by connecting to the unit via web browser.

V DAT (Voltage Disruption Analysis Tool) is a quantum leap in the field of power systems data interpretation. By harnessing state-of-the-art algorithms and processing techniques, V DAT effortlessly translates complex power data into discernible, actionable insights. V DAT tackles a major industry challenge: while traditional waveform captures are often intricate and challenging to interpret, V DAT brings clarity with its intuitively designed plots based on Information Technology Industry Council (ITIC) standards, empowering professionals to make quick and informed decisions.

In the test below, the STS was connected to two sources 150 degrees out-of-phase. Source 2 breaker was opened, causing the STS to perform an automatic transfer to the primary source. A delayed transfer occurred, causing events on Phases A, B, and C, automatically generating ITIC plots. Unlike waveform captures, ITIC plots are easy-to-read, and do not require expert analysis to understand.

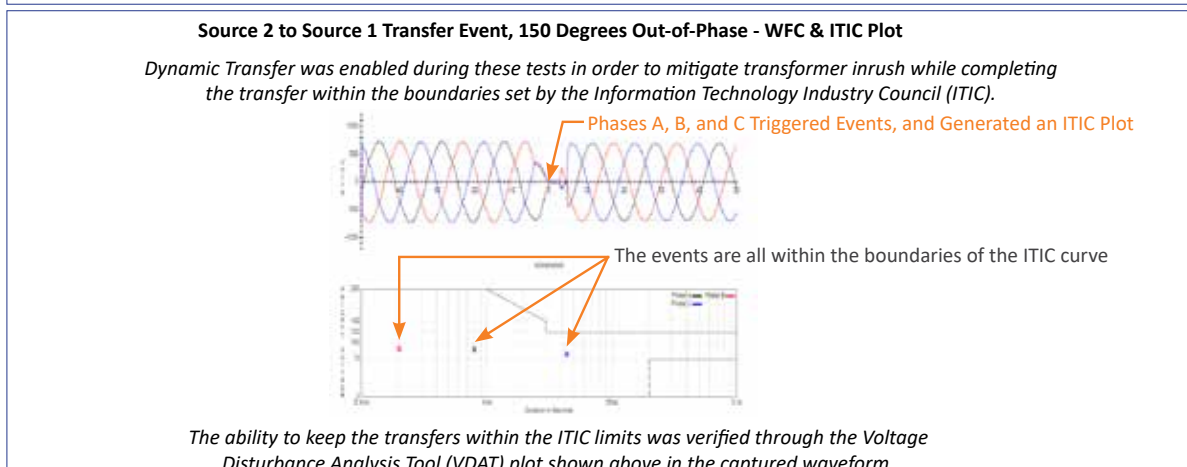
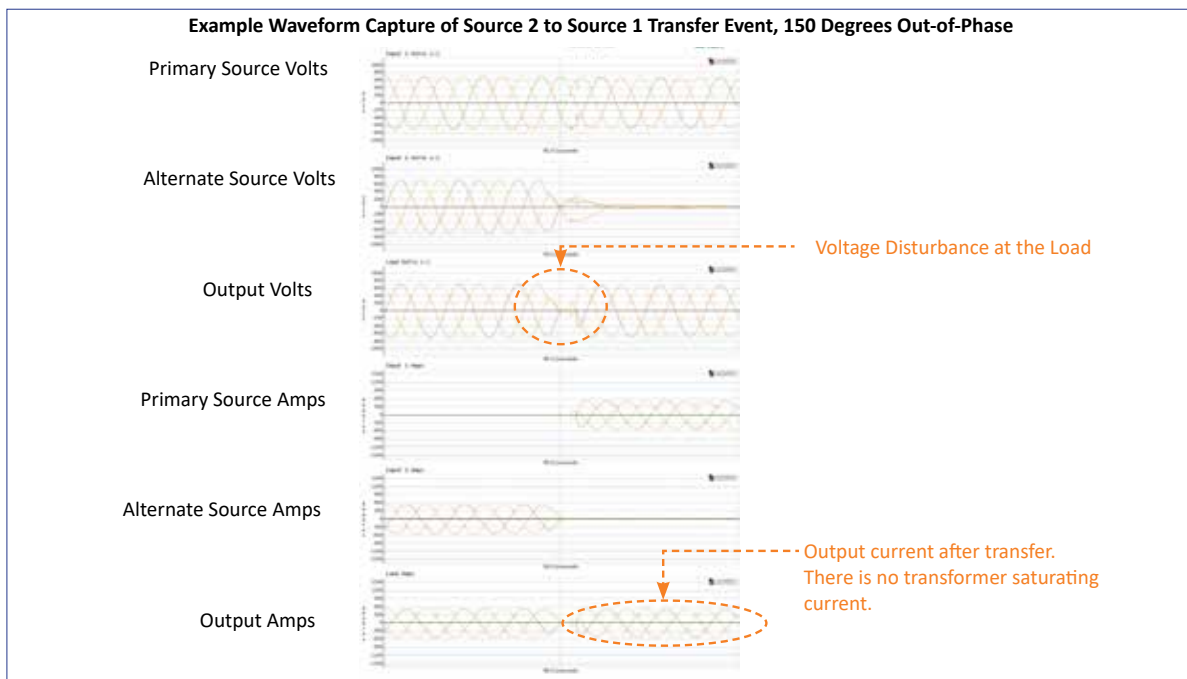

Power Quality Monitoring

Static Switch Power Quality Monitoring

The Series 70: eSTS is equipped with LayerZero SSQM (Static Switch Quality Monitoring), an all encompassing monitoring system with local and remote communications options.

From basic monitoring & alarm reporting, to advanced power quality monitoring functionality, LayerZero's SSQM provides a wide-range of options to help you be aware, be vigilant, be proactive in your quest to create a safe, stable and reliable operation.



eSTS Touch Screen GUI showing Real Time Waveform Capture

LayerZero's SSQM Provides Answers

LayerZero SSQM provides timestamped pictures of waveforms before and after events, providing information that enables facilities to go back in time to methodically identify and correct the root causes of events. LayerZero actively captures power quality information at the STS, PDU, and RPP - permitting thorough post-event analysis.

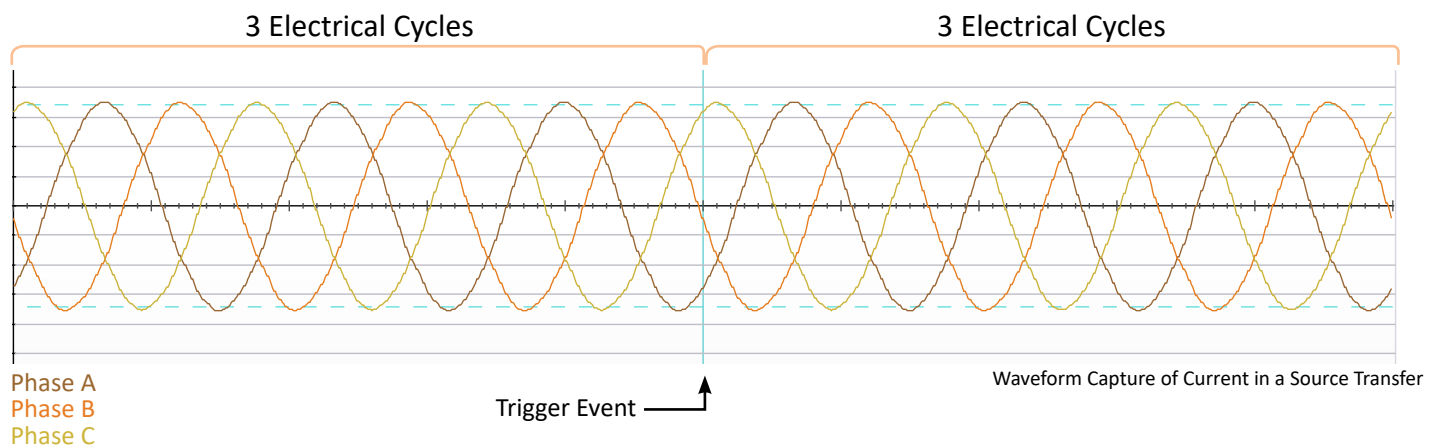

LayerZero SSQM Technical Specifications

LayerZero SSQM Parameters		Mains
Voltage Inputs and Output	Voltage (Volts)	✓
	Voltage Average of Phases (Volts)	✓
	Frequency (Hertz)	✓
	Total Harmonic Distortion (Percent VTHD)	✓
	Phase Rotation	✓
Current Inputs	Current (Amps)	✓
	Current Average of Phases (Amps)	✓
	Current Imbalance (Percent)	✓
	Real Power (kilowatts)	✓
	Apparent Power (kilovolt-amperes)	✓
	Reactive Power (kilovolt-amperes reactive)	✓
	Power Factor	✓
	Crest Factor	✓
	Crest Factor Average of Phases	✓
	Phase Difference Between Sources	✓
	Phase Difference Between Sources and Output	✓
Alarms	Summary Alarm	✓
	On Source (1/2/3)	✓
	Source Fail (1/2/3)	✓
	Source Preferred (1/2/3)	✓
	Source 1st Alternate (1/2/3)	✓
	Source Over/Under Voltage (1/2/3)	✓
	Source Over/Under Frequency (1/2/3)	✓
	Source Not Available (1/2/3)	✓
	Output Failure	✓
	Source Overcurrent (1/2/3)	✓
	Source Exceeds Manual Limit (1/2/3)	✓
	Source Exceeds Automatic Limit (1/2/3)	✓
	Bypassed to Source (1/2/3)	✓

Technical Specifications: 3-Pole Static Transfer Switch

Mechanical Characteristics *	
Current/Voltage/Number of Poles	400 A 480 V 3-Pole
Heat Dissipation	4,800 BTU/Hr
Weight	1,350 lbs (620 kg)
Dimensions	48"W x 36"D x 90"H (1210 mm x 914 mm x 2300 mm)
Clearances	Front: 36" (914 mm) Rear: 0" Sides: 0" Top: 18" (457 mm)
Frame Construction	Welded Frame
Electrical Connections	Silver-Plated Solid Busbar
Color	Textured Powder Coat White (RAL 7035), Blue (RAL 5017), Black, Custom
Floor Stands	Optional
Seismic floor stands	Optional
Junction Boxes	Optional
Sectionalization	Engineered Composite Insulation, Dead Front Doors
Electrical Characteristics	
Number of Inputs	2, 3 (3 optional)
Number of Output CBs	1, 2
Frequency	50 Hz, 60 Hz
Poles	3-pole
Phases	3 Phase, 3 Wire, 4 Wire + Ground
Neutral Rating	100%, 150%, 200%
Transfer Time	Nominal 1/4- cycle for in-phase sources
Redundancy	Single Module Redundancy, Triple Modular Redundancy (Optional)
Circuit Breaker Type	Molded Case Switch (Standard), Electronic Trip (Optional)
Circuit Breaker Mounting Type	Plug-In up through 600 A; Draw-out 800 A, 1200 A
TVSS	Standard
Power Quality Monitoring	
Power Quality Monitoring Technology	LayerZero Power Quality Monitoring
Waveform Capture	Local Display, Remote Display via Web Browser, Waveforms Automatically Emailed
Voltmeter	Input sources and Output, for each phase
Ammeter	Input sources and Output, for each phase
Frequency Meter	Both Sources
Synchroscope	Phase Angle Meter Between Sources
Metering	Apparent Power, Real Power, Power Factor, Output Total Harmonic Distortion
Time Stamped Transfer Count	From First Day Use, From Last Reset
CB Status Indicator	Open/Closed/Tripped Circuit Breaker
Source Indicator	Preferred Source
Power Path Indicator	On Live Mimic

*Dimensional & weight data is only valid for 2-source.

All product specifications are subject to change without notice.

Technical Specifications

Operational Characteristics	
Transfer Modes	Automatic; Manual (via Preferred Source Selection)
Inrush Mitigation Technology	Patented Dynamic Phase Compensation Algorithm (U.S. Patent 7,589,438 B2)
Cooling	Convection Cooling
Cable Access	Top/Bottom
Service Access	Front Only
Bypass Interlock Mechanism	Mechanical
Noise & Interference Isolation	Optical Fiber in Critical Control Paths
IR Scan Port Type	INSIGHT IR® Portholes
SCR Type	Puck
Display Type	15" Color Touch Screen
Display Resolution	1024x768
Bypass Assistance	Voice-Guided Bypass
Audio	Bezel-Mounted Stereo Speakers
Languages	English, French
Mimic Panel	Digital
Setpoints Control	Digital
Power Supplies	Redundant (4 Failure Groups. Triple Redundant Supplies. 12 Power Supplies Provided.)
Connectivity	
Meters	Local Display, Ethernet, Modbus/TCP, http via Web Browser (Non-Proprietary)
Alarms	Local Display, Ethernet, Modbus/TCP, http via Web Browser (Non-Proprietary)
Summary Alarm	Dry Contacts; Local Display; Modbus/TCP; Web Browser
Waveforms	Local Display, Ethernet, http via Web Browser (Non-Proprietary)
History/Event Log	Local Display, Ethernet, http via Web Browser (Non-Proprietary)
Diagnostics	Local Display, Ethernet, http via Web Browser (Non-Proprietary)
Time Synchronization	Network Time Protocol (NTP)
Standards Conformance	
CSA	ETL Listed to C22.22 No 107.
UL	ETL Listed to UL 1008S

All data tables above are for 3-pole only. Contact LayerZero for custom sizes and designs.

All product specifications are subject to change without notice.

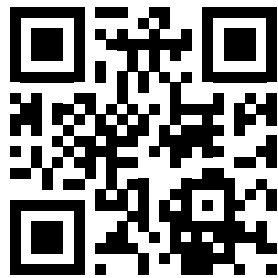

Learn more at www.LayerZero.com



LayerZero Power Systems, LLC.
1500 Danner Drive
Aurora, OH 44202 U.S.A.

© 2026 LayerZero Power Systems, LLC.

[LayerZero](#)®, INSIGHT IR®, SAFEARM®, SAFEPANEL®, and LayerZero Power Systems, LLC.® are registered trademarks of LayerZero Power Systems, LLC. All Rights Reserved.

All product specifications are subject to change without notice.

Rev. 4/26 #18