



LAYERZERO
POWER SYSTEMS, LLC.

The Foundation Layer

Series 70: eRDP

Web Enabled Remote Distribution Panel



Product Brochure

The LayerZero eRDP Remote Distribution Panel Maximizes Power Reliability

eRDP Is Inspired by NFPA-70E

The Series 70 eRDP is a Remote Distribution Panel designed for critical environments. Designed for NFPA 70E principles in mind, it features an open layout and an IP-20 rated Finger-Safe SafePanel® to enhance operator safety. With a focus on reliability, connectivity, and advanced power quality monitoring, the Series 70 eRDP delivers dependable performance for mission-critical operations. Its flexible design makes it ideal for facilities that continue to evolve and expand.

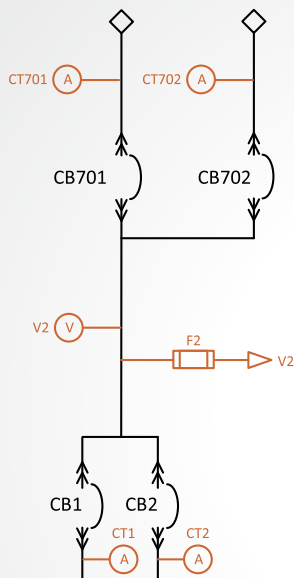

One Line Diagram

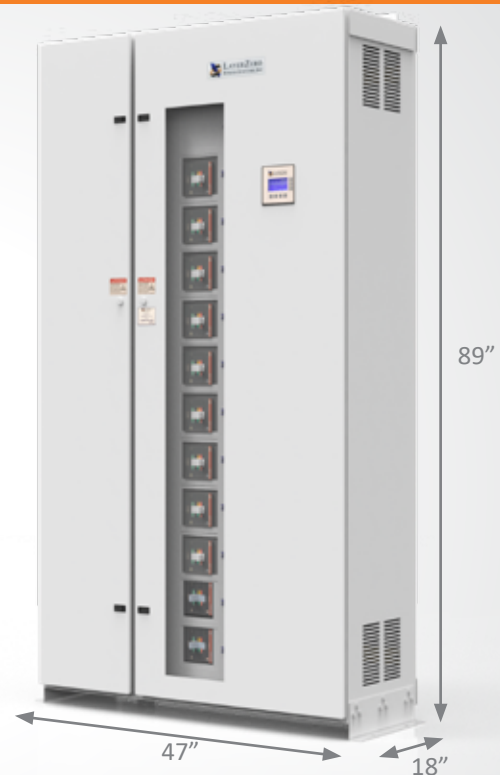

Reliability



Silver Plated Terminals:
Silver Has Excellent Conductivity To Provide Superior Electrical Performance and Reliability



Convection Cooling:
Natural Convection-Cooled Heat Dissipation System is Maintenance-Free



Machined Hardware:
Machined Cap Screws and Engineered Disc Springs Maintain Constant Torque Throughout Product Life



Selective Trip Coordination:
Main Breaker Will Not Trip In The Event of a Downstream Fault.



Serialized Critical Board Tracking:
Critical Boards Are Serialized And Cataloged in an Active Database For Traceability

Safety



INSIGHT IR® Cameras:
Built-in Infrared Cameras to Continuously Scan Bolted Connections For Irregular Rises In Temperature



Sectionalized Components:
Separations Between Each Section To Maintain Maximum Operator Safety



Polycarbonate Windows:
Allows Critical Board LEDs To Be Viewed With The Dead-Front Door Closed



Guided Wireways:
Helps Keep Wires Organized



Dead Front Hinged Doors:
Barrier To Provide A Safe Working Area With No Exposed Live Parts



SafePanel® Distribution:
IP-20 Rated Finger-Safe Panel Board with No Exposure to Exposed Live Parts

Connectivity

Ethernet Connectivity:
Secure VPN Router Connects To Network For Advanced Remote Monitoring Capabilities

Modbus/TCP:
Open Connectivity to Existing Monitoring Systems Without Proprietary Limitations

NTP Time Clock Synchronization:
Facilitates Timeline-Based Logging For Post-Event Reconstruction

SNMP Connectivity:
Permits Remote Management Via Simple Network Management Protocol

Dry Contacts:
Access Alarms Data with Dry Contacts Connections

Power Quality Monitoring

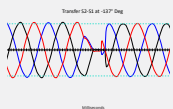

Real-Time Waveform Capture:
Automatically Captures A Picture Of The Power Six-Cycles Before and After Every Event

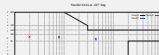

ITIC Plotting:
Generate ITIC Plots To Determine if Connected Equipment Was Affected by Power Quality Events



Optional Local Touch-Screen Interface:
Password-Protected Color Touch-Screen GUI For Local STS Setup/Operation/Administration

Equipment Layout

Main Circuit Breaker Section:

Louvered Vents:
Convection-Cooled Exhaust

Monitoring/Distribution Section:

LCD Membrane Panel
Color-Touch Screen Interface
(Optional)

Polycarbonate Window:
View CB Positions
with Door Closed

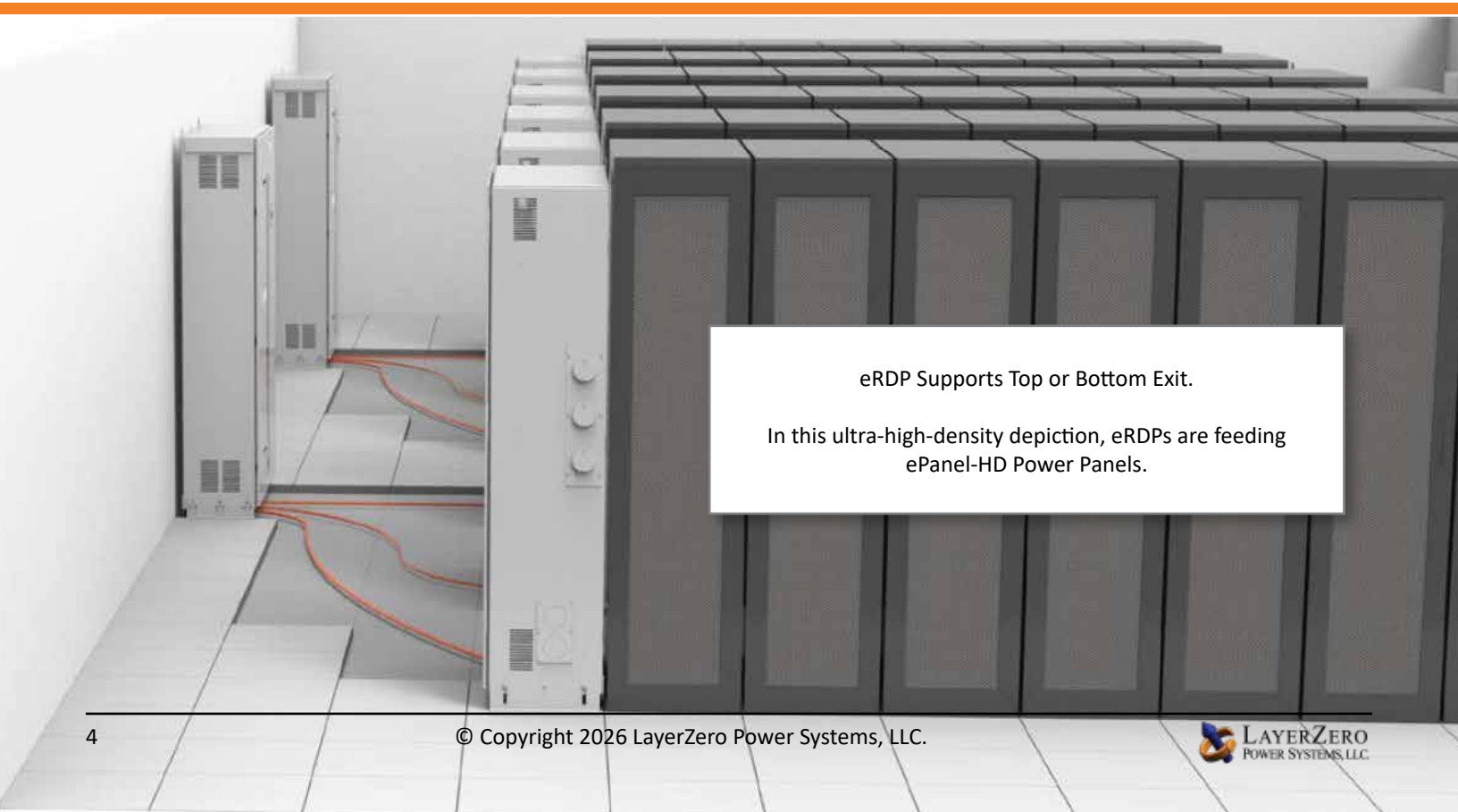
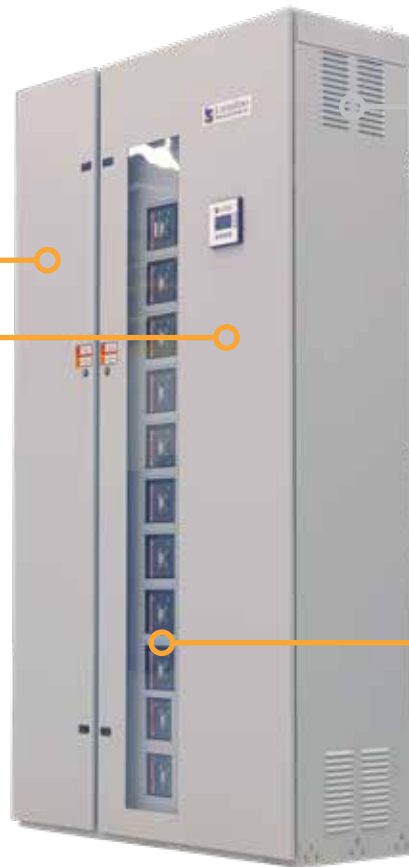

eRDP Supports Top or Bottom Exit.

In this ultra-high-density depiction, eRDPs are feeding
ePanel-HD Power Panels.

Equipment Construction Detail

1. Hinged Dead Front Doors
2. Silver Plated Terminals
3. LayerZero Monitoring Local Display
4. Polycarbonate Window
5. INSIGHT IR® Portholes
6. Convection Cooled Exhaust
7. Main Circuit Breaker
8. Branch Circuit Breakers
9. CTs For Power Quality Monitoring
10. LayerZero DPQM Controls
11. Guided Wireways for Organized Cabling

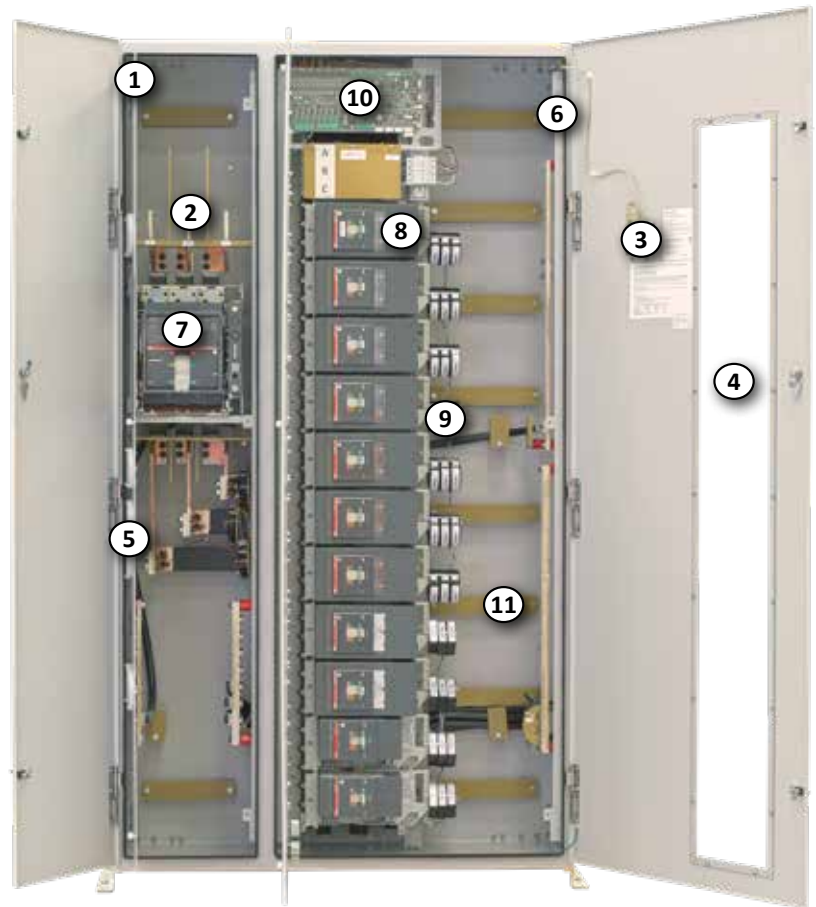

4. Alarm Indicator
5. PBM Status Indicator
6. Logged In User
7. Navigation Menu



Reliability Features

Silver Plated Terminals

All input terminals feature silver plating for optimal performance. Silver's high conductivity and low resistance ensure superior contact quality and long-term reliability.



Silver-Plated Customer Connections

Machined Hardware

Bolted connections use machined cap screws and engineered disc springs, maintaining consistent torque throughout the product's life. Tested across wide temperature ranges, these connections remain stable and secure under varying conditions.



Machined Cap Screws and Engineered Disc Springs Utilized in LayerZero Power Systems Products

View CB Positions With Dead-Front Doors Closed

The Series 70 eRDP includes polycarbonate windows on the outer door of the subfeed circuit breaker section, allowing operators to view breaker positions safely with the dead-front door closed.



Polycarbonate Window in the eRDP

Safety Features/Ease of Maintenance

Scan Bolted Connections with Dead-Front Doors Closed

Strategically placed IR-scan portholes allow safe thermal scanning of all bolted connections with the dead-front doors closed, eliminating operator exposure to live voltage.

Each IR window swivels upward and unlocks with keyhole access to reveal a mesh, enabling accurate, point-and-shoot thermal imaging. LayerZero provides detailed documentation to guide proper scanning procedures.



INSIGHT IR® Portholes on the eRDP

Guided Wireways

Integrated guided wireways and cable clips help maintain clean, organized routing of cables and wiring throughout the panel.



Guided Wireways help keep cables organized

Sectionalization Maximizes Operator Safety

The eRDP's sectionalized design ensures operators remain protected from energized connections. Operator-access areas are physically separated from power and control electronics, allowing maintenance to be safely performed on individual sections. If servicing is required, power can be redirected to another section for uninterrupted operation. Once installed, there is no need to open the left cabinet.



Sectionalized Components to Maximize Safety

Safety Features

The LayerZero SafePanel®

The Series 70 eRDO features an IP-20, finger-safe panel board designed to prevent ingress of objects larger than ½ inch (12.5 mm), ensuring maximum operator protection.

During breaker removal or separation of live conductors, an arc may form. However, the SafePanel® design contains any potential arc within the connection well.

Deeply insulated and isolated components make breaker removal both safe and straightforward, reinforcing LayerZero’s commitment to operator safety and system reliability.



Finger-Safe SafePanel® Subfeed Panel Board

eRDP 1200 A Circuit Breaker Installation Process



The Breaker Is Inserted Into The SafePanel



The Handle Is Unlocked



Screws Help Secure The Breaker



For Maximum Safety, The SafePanel Has Recessed Bus Work and Finger Safe Lattice.

Power Quality Monitoring



The Series 70 eRPP is equipped with LayerZero DPQM (Distribution Power Quality Monitoring), an all-encompassing system offering both local and remote communication options.

From basic monitoring and alarm reporting to advanced power quality analysis, DPQM provides the tools to help you stay awake, vigilant, and proactive in maintaining a safe, stable, and reliable operation.



A color touch screen GUI is optional

LayerZero DPQM Provides Answers

DPQM delivers timestamped waveform captures before and after every event, giving facilities the ability to analyze incidents and identify root causes with precision. Power quality data is continuously recorded at the STS, PDU, and RPP levels, supporting thorough post-event investigation and long-term reliability improvements.

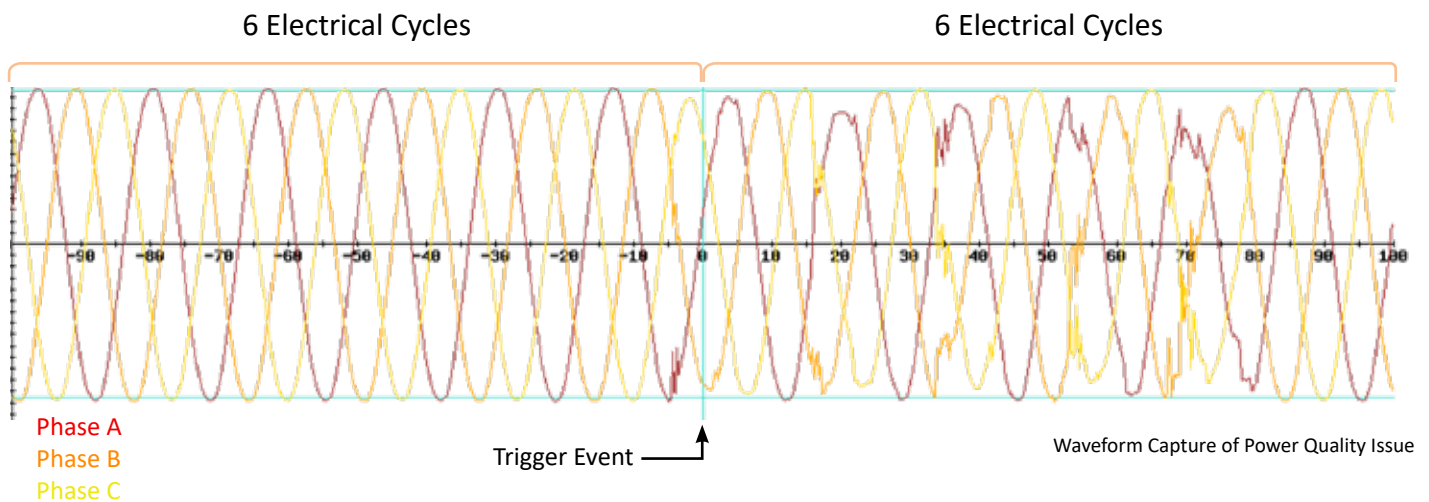

Power Quality Monitoring

LZ DPQM

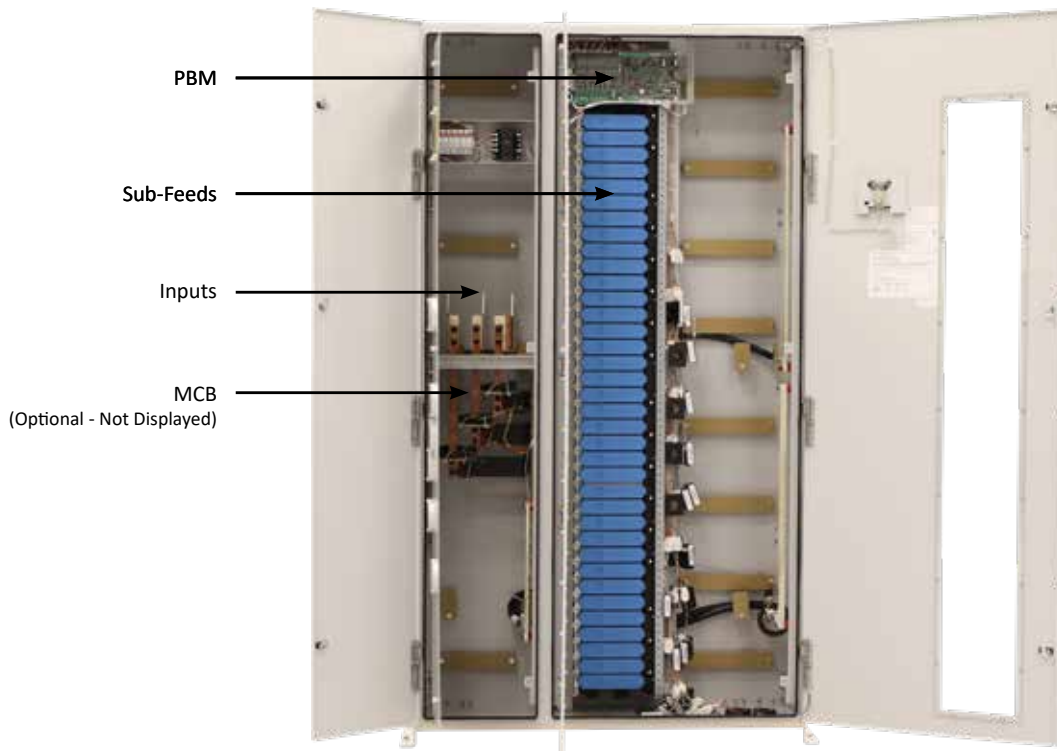
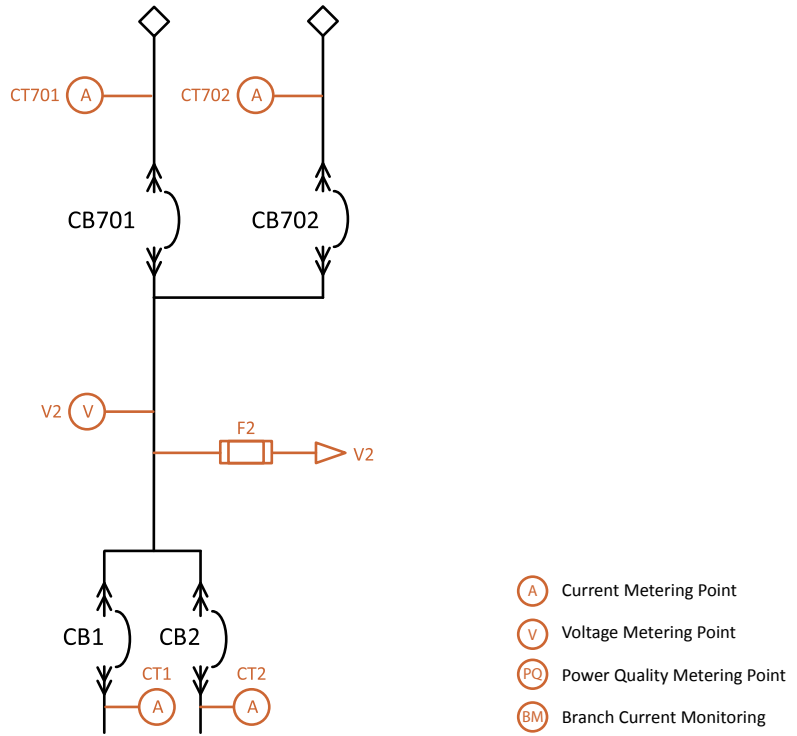

Technical Specifications



LayerZero DPQM Parameters		Mains	Subfeeds or Branch Circuits
Voltage Monitor	Volts (L-L) Phase A/B/C (volts RMS)	✓	
	Volts (L-N) Phase A/B/C (volts RMS)	✓	
	Phase Rotation	✓	
Current Monitor	CT Reversed Phase A/B/C/N	✓	✓
	Current Phase A/B/C/N (amperes RMS)	✓	✓
Power Monitor	Frequency (hertz)	✓	
	Real Power (kilowatts)	✓	✓
	Apparent Power (kilovolt-amperes)	✓	✓
	Reactive Power (kilovolt-amperes reactive)	✓	✓
	Power Factor	✓	✓
	Energy (kilowatt-hours)	✓	✓
	Block Demand (kilowatts)	✓	✓
	Block Demand Peak (kilowatts)	✓	✓
	Rolling Demand (kilowatts)	✓	✓
	Rolling Demand Peak (kilowatts)	✓	✓
Power Quality	Percent VTHD (percent)	✓	✓
	Waveform Capture	✓	✓
Alarms	Phase - Under Voltage A/B/C (Alarm)	✓	
	Phase - Over Voltage A/B/C (Alarm)	✓	
	Phase - Low Voltage A/B/C (Warning)	✓	
	Phase - High Voltage A/B/C (Warning)	✓	
	Phase - Over Current A/B/C (Alarm)	✓	✓
	Phase - High Current A/B/C (Warning)	✓	✓
	Under Frequency (Alarm)	✓	
	Over Frequency (Alarm)	✓	
	High VTHD (Warning)	✓	
	Over VTHD (Alarm)	✓	
	Phase Rotation (Alarm)	✓	

All product specifications are subject to change without notice.

All LayerZero products sample power sources for detailed power quality insights, accessible remotely via a web browser.

During testing, such as the “voltage sag” example shown, each phase’s voltage is monitored and plotted in real time. When the voltage drops below a user-defined setpoint, the system automatically records a waveform capture and generates an ITIC plot.

Waveforms and ITIC data are captured for every phase, on every circuit, for every event, ensuring complete visibility into system performance.

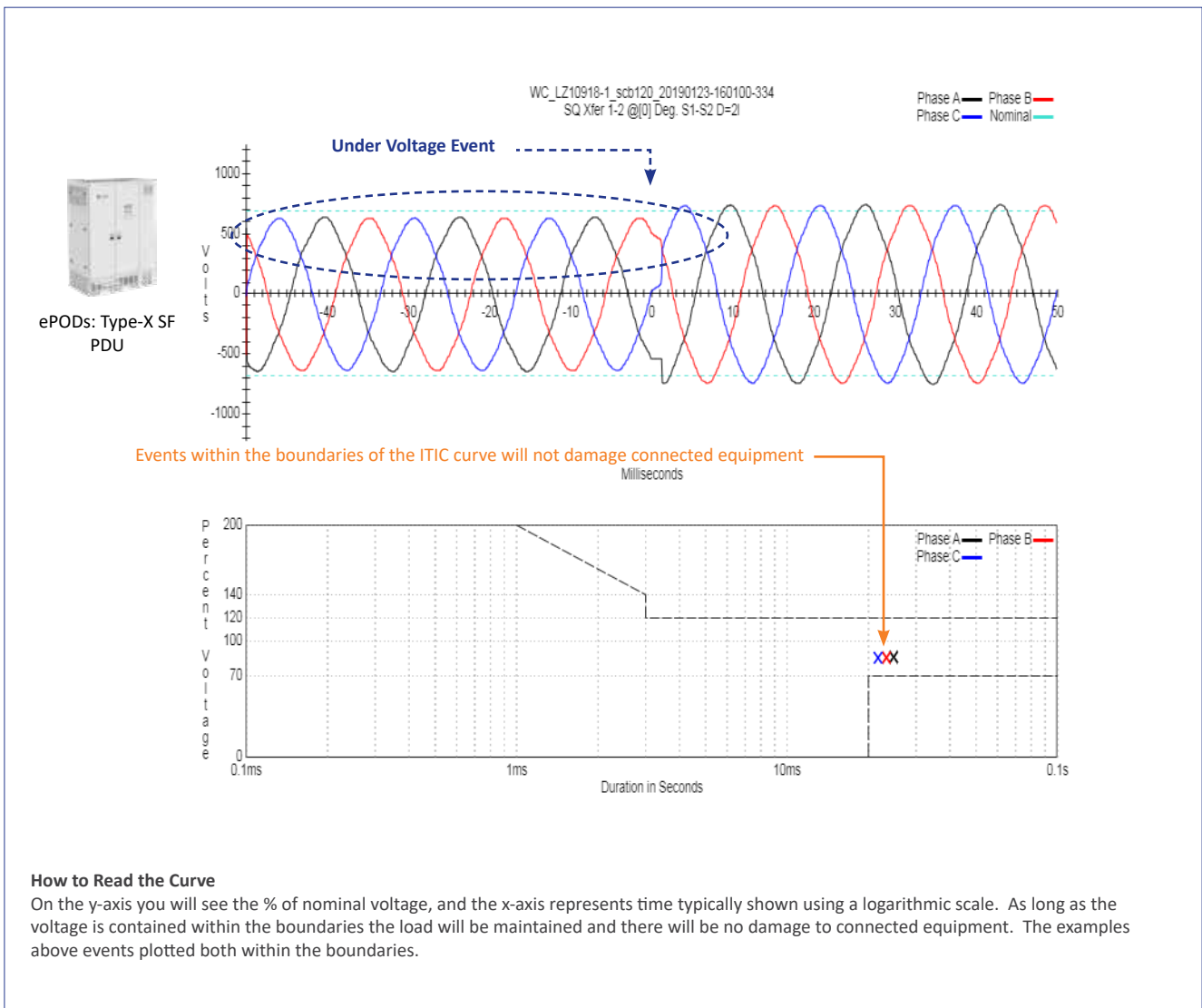

Technical Specifications

eRDP Models with System Withstand Ratings	
120/208V, 3-Phase, 4-Wire + Ground	100 kA
220/380V, 3-Phase, 4-Wire + Ground	
230/400V, 3-Phase, 4-Wire + Ground	
240/415V, 3-Phase, 4-Wire + Ground	65 kA
277/480V, 3-Phase, 4-Wire + Ground	
480V, 3-Phase, 3-Wire + Ground	42 kA
575V, 3-Phase, 3-Wire + Ground	
600V, 3-Phase, 3-Wire + Ground	

Mechanical Characteristics	
Dimensions	47"W x 89"H x 18"D (1194 mm x 2260 mm x 457 mm)
Weight	912 lbs (414 kg)
Enclosure Mounting	Wall-Mounted
Frame Construction	Welded Frame
Electrical Connections	Flexible Laminated Bus, Silver-Plated Solid Busbar
Color	Textured Powder Coat White (RAL 7035), Blue (RAL 5017), Black, Custom
Seismic Floor Anchors	Optional
Seismic Floor Stand	Optional
Sectionalization	Engineered Composite Insulation, Dead Front Doors
Circuit Breaker Identification	Labels Viewable Through Polycarbonate Window

Electrical Characteristics	
Input Voltage	120/208V, 3-Phase, 4-Wire + Ground; 220/380V, 3-Phase, 4-Wire + Ground; 230/400V, 3-Phase, 4-Wire + Ground; 240/415V, 3-Phase, 4-Wire + Ground; 277/480V, 3-Phase, 4-Wire + Ground; 480V, 3-Phase, 3-Wire + Ground; 575V, 3-Phase, 3-Wire + Ground; 600V, 3-Phase, 3-Wire + Ground
Withstand	100 kA
Configuration	Parallel (P), Shared Parallel (SP), Dedicated (D), Feed Through (FT)
Frequency	50 Hz, 60 Hz
Poles	3-pole, 4-pole
Neutral Rating	100%, 200%
Circuit Breaker Type	Electronic Trip, Molded Case Switch
Distribution	SafePanel® Distribution

Power Quality Monitoring	
Power Quality Monitoring Technology	LayerZero DPQM (Distribution Power Quality Monitoring)
Waveform Capture	Local Display, Remote Display via Web Browser

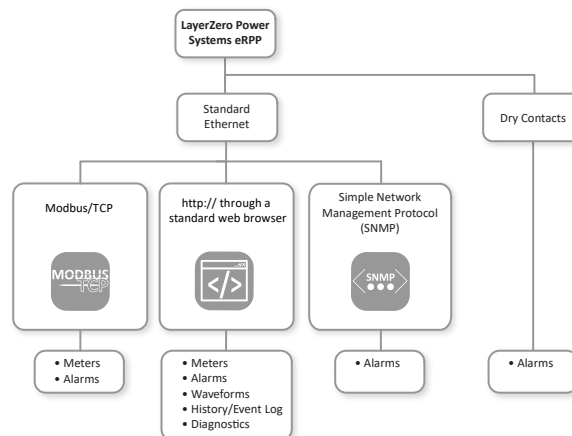

All product specifications are subject to change without notice.

Technical Specifications

Operational Characteristics	
Cooling	Convection Cooling
Cable Access	Top/Bottom
Service Access	Front Only Access
IR Scan Port Type	INSIGHT IR® Portholes
Display Type	3.2" LCD with Membrane, 10.5" Color Touch Screen GUI (Optional)
Connectivity	
Meters	Local Display, Ethernet, Modbus/TCP, http via Web Browser (Non-Proprietary)
Alarms	Local Display, Ethernet, Modbus/TCP, http via Web Browser (Non-Proprietary)
Summary Alarm	Dry Contacts
Waveforms	Local Display, Ethernet, http via Web Browser (Non-Proprietary)
History/Event Log	Local Display, Ethernet, http via Web Browser (Non-Proprietary)
Diagnostics	Local Display, Ethernet, http via Web Browser (Non-Proprietary)
Time Synchronization	Network Time Protocol (NTP)
Standards Conformance	
UL	ETL and cETL listed to UL 60950
Number of Output Circuit Breakers	
Number of Available SafePanel® Slots	36
CB Rating	Number of Slots Required
100 AF	2
250 AF	3
400 AF	3
400 AF 100%	6
800 AF	6

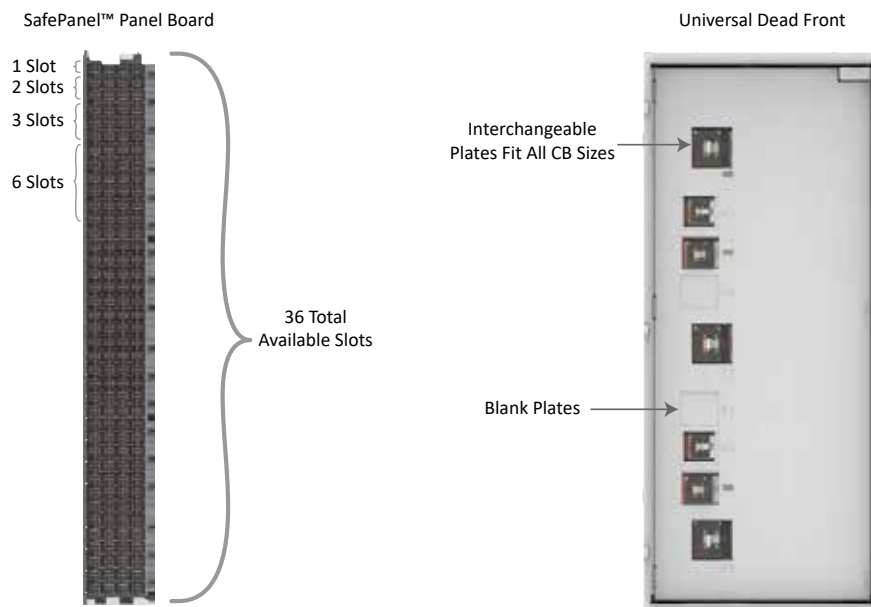

All product specifications are subject to change without notice.

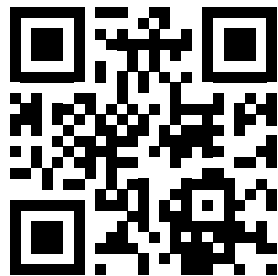

Learn more at www.LayerZero.com



LayerZero Power Systems, LLC.
1500 Danner Drive
Aurora, OH 44202 U.S.A.

© 2026 LayerZero Power Systems, LLC.

[LayerZero](#)®, INSIGHT IR®, SAFEARM®, SAFEPANEL®, and LayerZero Power Systems, LLC.® are registered trademarks of LayerZero Power Systems, LLC. All Rights Reserved.

All product specifications are subject to change without notice.

Rev. 4/26 #17